

CONSTRUX[®]
Mini PEEK and PTC Spacer System

Operative Technique

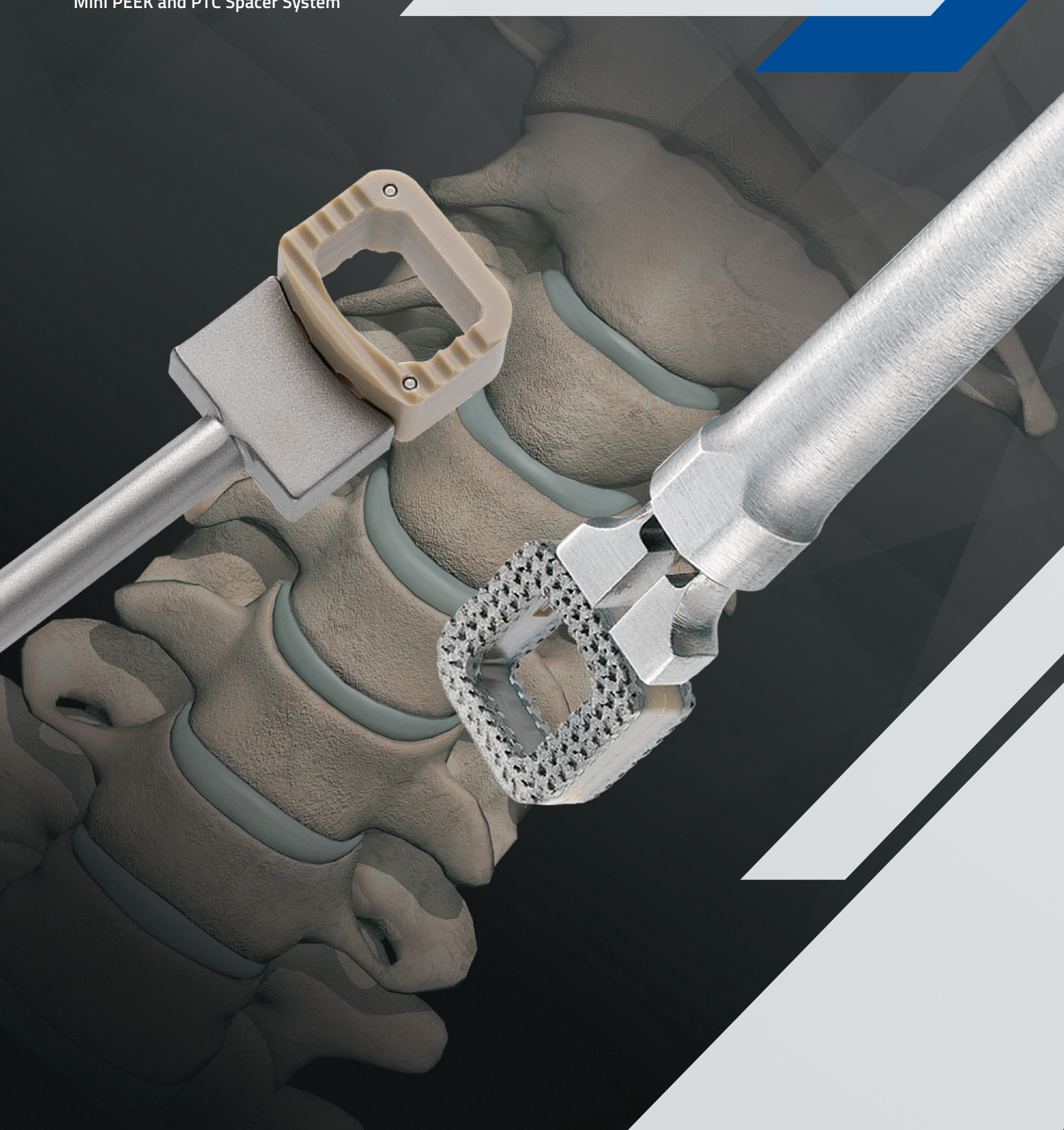

Table of Contents

1	Introduction
2	Operative Technique - Cervical Intervertebral Body
8	Operative Technique - Partial Intervertebral Body Replacement
13	Part Numbers

The surgical technique shown is for illustrative purposes only. The technique(s) actually employed in each case will always depend upon the medical judgment of the surgeon exercised before and during surgery as to the best mode of treatment for each patient. Please see the Instructions For Use for the complete list of indications, warnings, precautions, and other important medical information.

CONSTRUX[®]
Mini PEEK and PTC Spacer System

INTRODUCTION

The CONSTRUX® Mini Spacer System has been designed to optimize Anterior Cervical Procedures with surgeon designed implants and instruments. The CONSTRUX Mini Spacer System offers implants manufactured from either PEEK or PEEK Titanium Composite (PTC) materials. The CONSTRUX Mini PTC Spacers offer a proprietary technology that combines PEEK and titanium into a porous interbody solution for the cervical spine. The titanium endplates consist of open pores with optimized porosity and pore size to create a 3D porous material which may facilitate bone ingrowth. The PEEK core allows for intra- and post-operative imaging without image distortion compared to metal designs currently on the market. The CONSTRUX Mini PEEK and PTC systems both offer multiple implant options for various surgical solutions as well as straightforward instrumentation for easy implantation.

Design Advantages of the CONSTRUX Mini PEEK Spacers include:

- Radiolucent implant with titanium markers for intraoperative visibility
- Anti-migration ribs for secure placement
- Large center opening for packing bone grafting material

Design Advantages of the CONSTRUX Mini PTC Spacers include:

- Porous titanium endplates for potential bone ingrowth
- PEEK core to obtain imaging properties while assessing fusion
- Large center opening for packing bone grafting material

STERILIZATION

CONSTRUX Mini PTC Spacer implants are provided in a sterile package. Carefully confirm the implant size that you desire from the outside label prior to opening the box or inside trays. The implants are packaged in a double-tray with a peel-back lid for easy transfer into the sterile field. If the implant is opened and not used, the implant MAY NOT be sterilized and used again. The instruments utilized with this implant are the same instruments in the CONSTRUX Mini PEEK Spacer System. They are offered as non-sterile and should be sterilized prior to surgery.

CERVICAL INTERVERTEBRAL BODY

The following section demonstrates the procedure for Cervical Intervertebral Body technique

1. PREOPERATIVE PLANNING AND PATIENT POSITIONING

Preoperative planning is critical in the preparation process for spinal surgery. A complete radiographic evaluation (A/P and Lateral films) is recommended for proper diagnosis prior to surgery. Carefully position the patient in the supine position on the operating table ensuring all bony prominences are padded and the cervical spine is in a neutral to slightly extended position following the induction of anesthesia. **(Fig 1)**



Fig. 1

2. EXPOSURE/DISCECTOMY

The affected disc space is exposed using the appropriate anterior approach. The disc material is excised and both the superior and inferior endplates are prepared. **(Fig 2)**

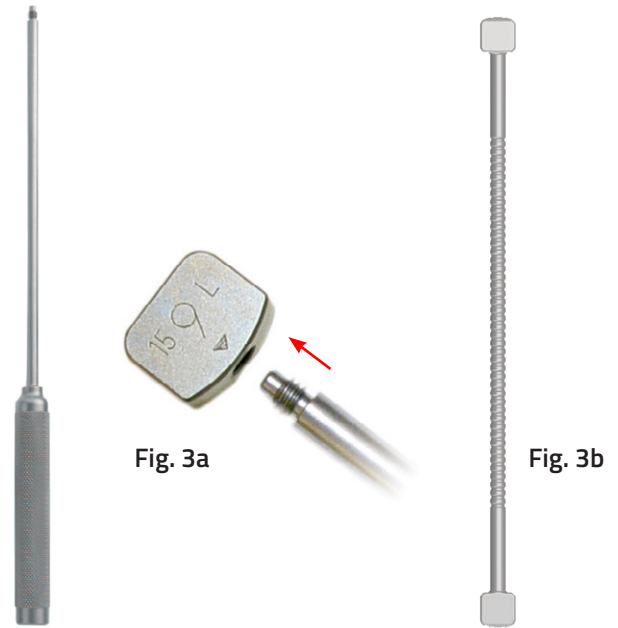

Fig. 2

3. IMPLANT SIZING

Selection of the proper implant is essential. Attach the trial inserter into the allotted screw hole in the trial. **(Fig. 3a)** Place the trials, in sequential order, into the disc space to determine the proper implant size (height, footprint and lordosis). The trial spacer should fit tightly between the endplates in footprint, height, depth and lordotic angle. The use of lateral fluoroscopy will assist in determining proper implant depth. The monolithic double ended trials may also be used to determine proper implant sizing **(Fig. 3b)**.

CAUTION: There is no depth limiting stop on the trials or rasp. Instruments should be impacted only as deep as intended for interbody spacer placement. Lateral fluoroscopy is recommended to confirm desired position of interbody.



4. RASPING

A rasp may be used to prepare the end plates. Move the rasp anterior/posterior and medial/lateral around the vertebral endplates until desired preparation is achieved **(Fig. 4)**.

NOTE: The rasps mirror the interbody footprint.

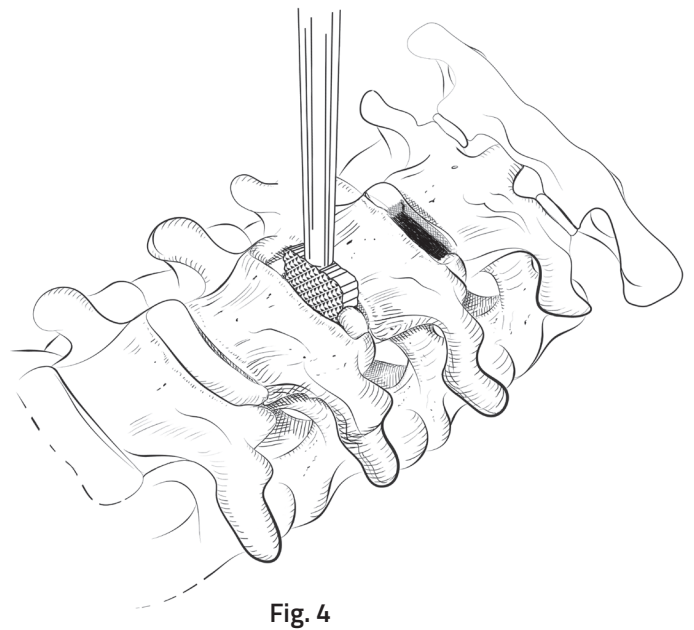

5. LOADING THE IMPLANT WITH IMPLANT INSERTER (47-1040)

Once the proper implant size has been determined, attach the implant to the implant inserter. This is achieved by un-threading the knob counterclockwise to ensure inserter is in the unlocked position. Slide the implant onto the prongs of the inserter.

(Fig. 5a) Thread the knob clockwise to lock the inserter and secure the implant. **(Fig. 5b)** The implant window is intended to be filled with autograft and/or allograft comprised of cancellous and/or corticocancellous bone graft to help promote fusion.

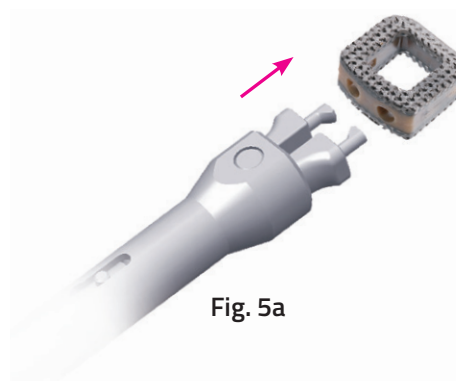

Fig. 5a

Fig. 5b



LOADING THE IMPLANT WITH MINI INSERTER (47-1030)

Once the proper implant size has been determined, attach the implant to the implant inserter. This is achieved by pressing the back of the inserter forward into the unlocked position. **(Fig. 5d)** Slide the implant onto the prongs on the inserter. **(Fig. 5c)** Release the back of the inserter to secure the implant.

The implant window is intended to be filled with autograft and/or allograft comprised of cancellous and/or corticocancellous bone graft to help promote fusion.

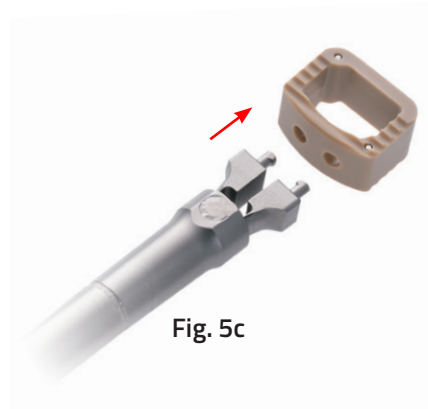

Fig. 5c

Fig. 5d



6. IMPLANT INSERTION

Insert the implant into the disc space. (**Fig. 6a**)
Under the guidance of fluoroscopy, the orientation of the implant can be assessed. If repositioning is needed, use the **Implant Impactor (30-1030)**.

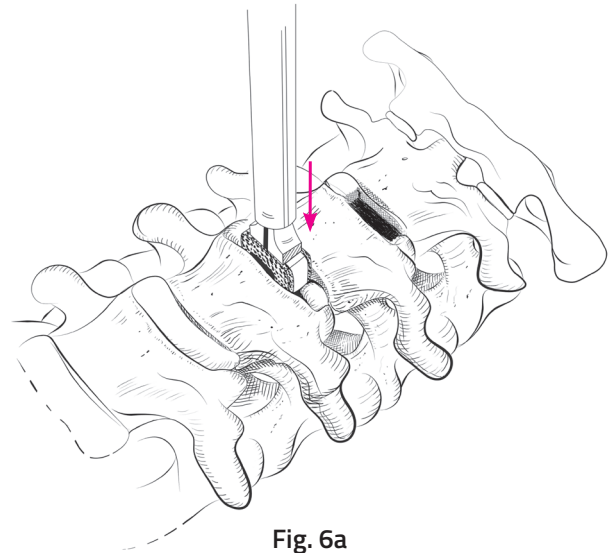

Fig. 6a

Repeat steps 2-6 for adjacent level implant
(**Fig. 6b**)

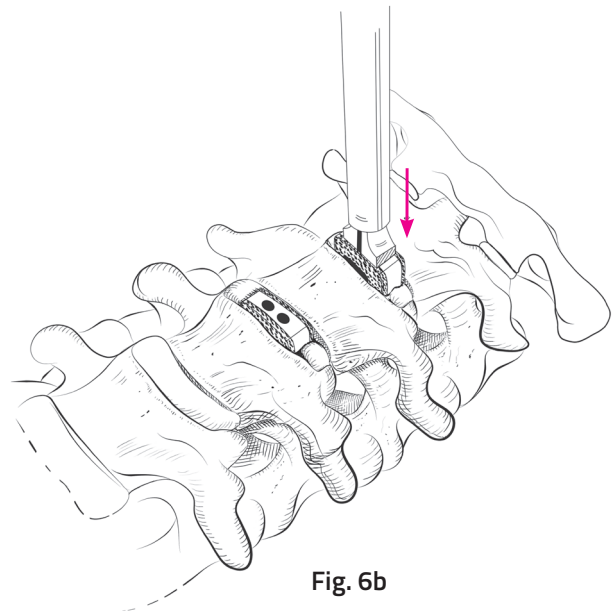

Fig. 6b

7. IMPLANT REMOVAL AND REVISION

If removal of the implant is required, use the implant inserter to re-engage the implant and pull the implant out of the intervertebral space. If necessary, distract the vertebrae inferior and superior to the implant for removal. (**Fig. 7a**)

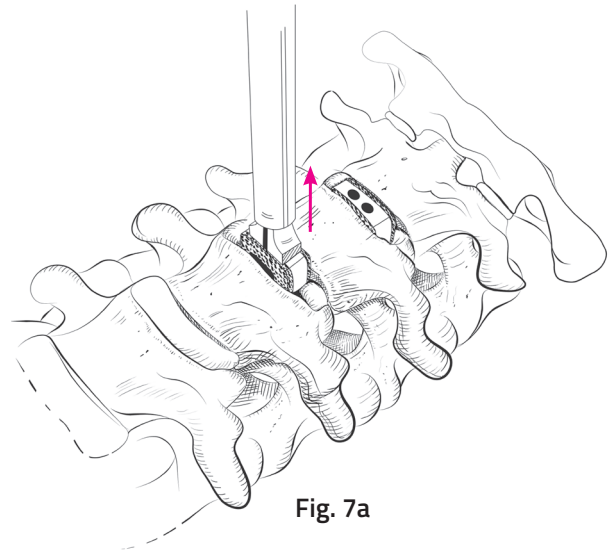

Fig. 7a

Repeat step 7 to remove adjacent level implant (**Fig. 7b**)

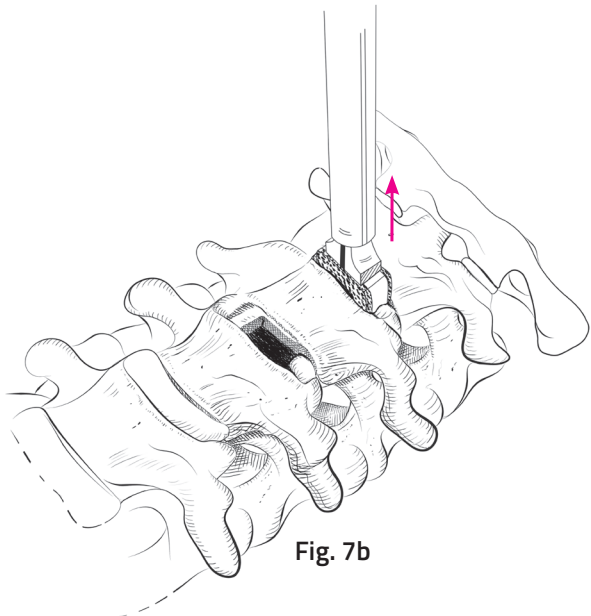

Fig. 7b

PARTIAL INTERVERTEBRAL BODY REPLACEMENT

The following section demonstrates the procedure for Partial Intervertebral Body Replacement technique for CONSTRUX Mini PEEK Spacer System.



1. PREOPERATIVE PLANNING AND PATIENT POSITIONING

Preoperative planning is critical in the preparation for spinal surgery. A complete radiographic evaluation (A/P and lateral films) measuring the vertebral body dimension is recommended for proper diagnosis prior to surgery.

Carefully place the patient in the supine position on the operating table with all bony prominences padded and the lumbar spine in neutral to slight extension following induction of anesthesia. **(Fig. 1)** Once the patient is placed on the table, use a lateral C-Arm fluoroscopy to visualize the lumbar spine.



Fig. 1

2. PARTIAL VERTEBRAL BODY REMOVAL

The traumatized or diseased vertebral body is exposed through the appropriate anterior approach. The affected partial vertebral body and disc material is excised and both superior and inferior surfaces are prepared. **(Fig. 2)**

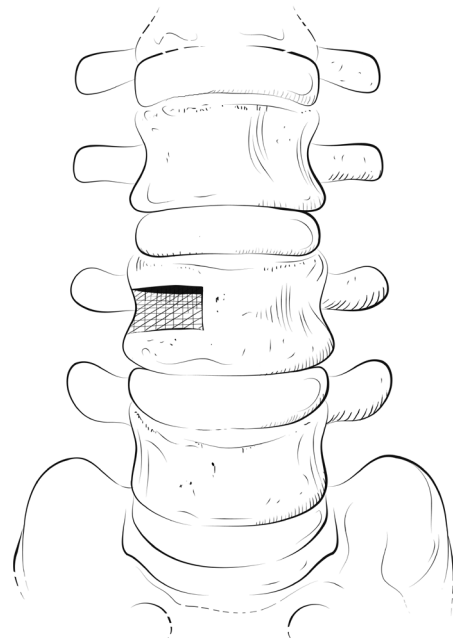

Fig. 2

3. IMPLANT SIZING

Selection of the proper implant is essential. Attach the trial inserter into the allotted screw hole in the trial. **(Fig. 3a)** Place the trials, in sequential order, into the affected space to determine the proper implant size (height, footprint and lordosis). The trial spacer should fit tightly between the endplates in footprint, height, depth and lordotic angle. The use of lateral fluroscopy will assist in determining proper implant depth. The monolithic double ended trials may also be used to determine proper implant sizing **(Fig. 3b)**.

CAUTION: There is no depth limiting stop on the trials or rasp. Instruments should be impacted only as deep as intended for partial VBR spacer placement. Lateral fluroscopy is recommended to confirm desired position of partial VBR.

NOTE: When used as a partial VBR device, the CONSTRUX Mini PEEK Spacer System is intended for use in affected vertebral body segments that are equal to or smaller than the size of the device. For larger affected vertebral body segments, a larger device indicated for partial or full VBR is recommended.

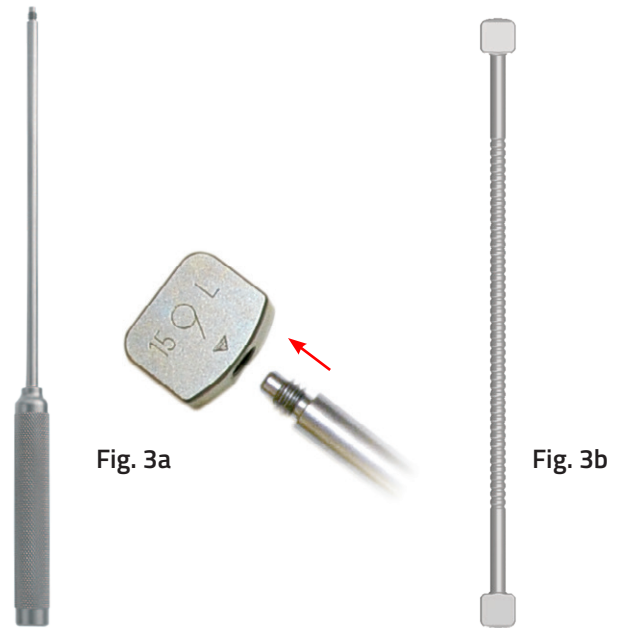

4. RASPING

A rasp may be used to prepare the end plates. Move the rasp anterior/posterior and medial/lateral around the vertebral endplates until desired preparation is achieved **(Fig. 4)**.

NOTE: The rasps mirror the implant footprint.

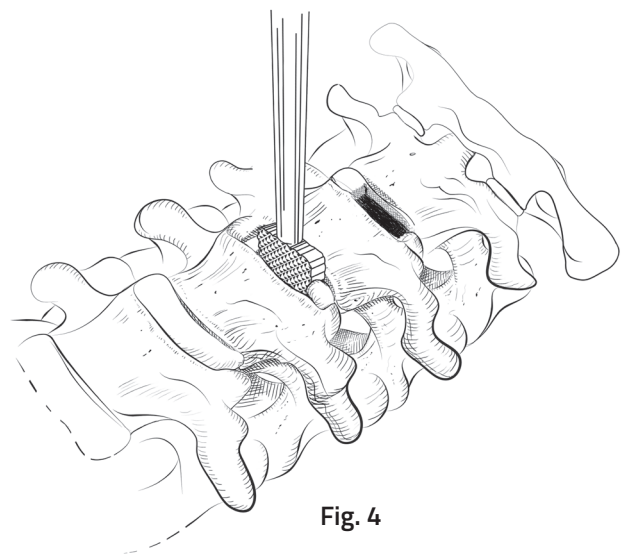

5. LOADING THE IMPLANT WITH IMPLANT INSERTER (47-1040)

Once the proper implant size has been determined, attach the implant to the implant inserter. This is achieved by un-threading the knob counterclockwise to ensure inserter is in the unlocked position. Slide the implant onto the prongs of the inserter.

(Fig. 5a) Thread the knob clockwise to lock the inserter and secure the implant. **(Fig. 5b)** The implant window is intended to be filled with autograft and/or allograft bone graft to help promote fusion.

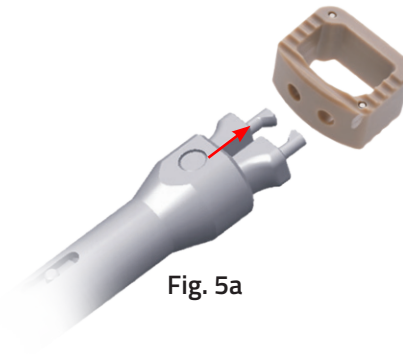

Fig. 5a



Fig. 5b

LOADING THE IMPLANT WITH MINI INSERTER (47-1030)

Once the proper implant size has been determined, attach the implant to the implant inserter. This is achieved by pressing the back of the inserter forward into the unlocked position. **(Fig. 5d)** Slide the implant onto the prongs on the inserter.

(Fig. 5c) Release the back of the inserter to secure the implant. The implant window is intended to be filled with autograft and/or allograft bone graft to help promote fusion.

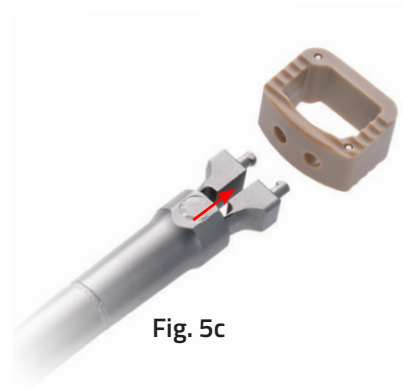

Fig. 5c



Fig. 5d

6. IMPLANT INSERTION

Insert the implant into the affected space. **(Fig. 6)**
Under guidance of fluoroscopy, the orientation of the implant can be assessed. If repositioning is needed, use the implant tamp.

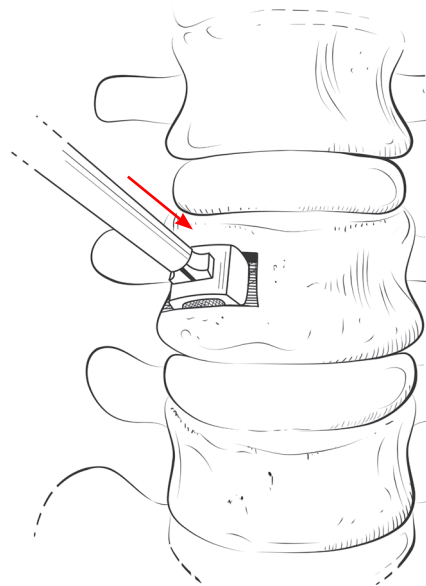

Fig. 6

7. IMPLANT REMOVAL AND REVISION

If removal of the implant is required use the implant inserter to re-engage the implant and pull the implant out of the affected space. **(Fig. 7)**
If necessary, distract inferior and superior to the implant for removal.

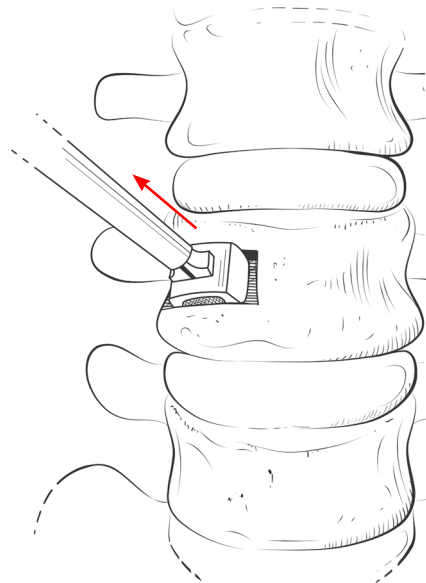

Fig. 7

Construx Mini PEEK Implant Caddy (OPTIONAL)
Part# 47-9113

12mm x 12mm Parallel Implants

Part #	Description	Graft Vol. (cc)
47-3105C	12mm W x 12mm L, Parallel - 5mm H	0.31
47-3106C	12mm W x 12mm L, Parallel - 6mm H	0.37
47-3107C	12mm W x 12mm L, Parallel - 7mm H	0.43
47-3108C	12mm W x 12mm L, Parallel - 8mm H	0.49
47-3109C	12mm W x 12mm L, Parallel - 9mm H	0.55
47-3110C	12mm W x 12mm L, Parallel - 10mm H	0.61
47-3111C	12mm W x 12mm L, Parallel - 11mm H	0.67
47-3112C	12mm W x 12mm L, Parallel - 12mm H	0.73
47-3113C	12mm W x 12mm L, Parallel - 13mm H	0.79
47-3114C	12mm W x 12mm L, Parallel - 14mm H	0.85

Construx Mini PEEK Implant Caddy (OPTIONAL)
Part# 47-9115

12mm x 12mm Lordotic Implants

Part #	Description	Graft Vol. (cc)
47-3005C	12mm W x 12mm L, 5° Lordotic - 5mm H	0.28
47-3006C	12mm W x 12mm L, 5° Lordotic - 6mm H	0.34
47-3007C	12mm W x 12mm L, 5° Lordotic - 7mm H	0.40
47-3008C	12mm W x 12mm L, 5° Lordotic - 8mm H	0.46
47-3009C	12mm W x 12mm L, 5° Lordotic - 9mm H	0.52
47-3010C	12mm W x 12mm L, 5° Lordotic - 10mm H	0.58
47-3011C	12mm W x 12mm L, 5° Lordotic - 11mm H	0.64
47-3012C	12mm W x 12mm L, 5° Lordotic - 12mm H	0.70
47-3013C	12mm W x 12mm L, 5° Lordotic - 13mm H	0.76
47-3014C	12mm W x 12mm L, 5° Lordotic - 14mm H	0.82

Construx Mini PEEK Implant Caddy (OPTIONAL)
Part# 47-9114

15mm x 12mm Parallel Implants

Part #	Description	Graft Vol. (cc)
47-4105C	15mm W x 12mm L, Parallel - 5mm H	0.43
47-4106C	15mm W x 12mm L, Parallel - 6mm H	0.51
47-4107C	15mm W x 12mm L, Parallel - 7mm H	0.59
47-4108C	15mm W x 12mm L, Parallel - 8mm H	0.67
47-4109C	15mm W x 12mm L, Parallel - 9mm H	0.76
47-4110C	15mm W x 12mm L, Parallel - 10mm H	0.84
47-4111C	15mm W x 12mm L, Parallel - 11mm H	0.92
47-4112C	15mm W x 12mm L, Parallel - 12mm H	1.00
47-4113C	15mm W x 12mm L, Parallel - 13mm H	1.08
47-4114C	15mm W x 12mm L, Parallel - 14mm H	1.17

Construx Mini PEEK Implant Caddy (OPTIONAL)
Part# 47-9116

15mm x 12mm Lordotic Implants

Part #	Description	Graft Vol. (cc)
47-4005C	15mm W x 12mm L, 5° Lordotic - 5mm H	0.38
47-4006C	15mm W x 12mm L, 5° Lordotic - 6mm H	0.47
47-4007C	15mm W x 12mm L, 5° Lordotic - 7mm H	0.55
47-4008C	15mm W x 12mm L, 5° Lordotic - 8mm H	0.63
47-4009C	15mm W x 12mm L, 5° Lordotic - 9mm H	0.71
47-4010C	15mm W x 12mm L, 5° Lordotic - 10mm H	0.79
47-4011C	15mm W x 12mm L, 5° Lordotic - 11mm H	0.88
47-4012C	15mm W x 12mm L, 5° Lordotic - 12mm H	0.96
47-4013C	15mm W x 12mm L, 5° Lordotic - 13mm H	1.04
47-4014C	15mm W x 12mm L, 5° Lordotic - 14mm H	1.12

*Items in blue available upon request only.

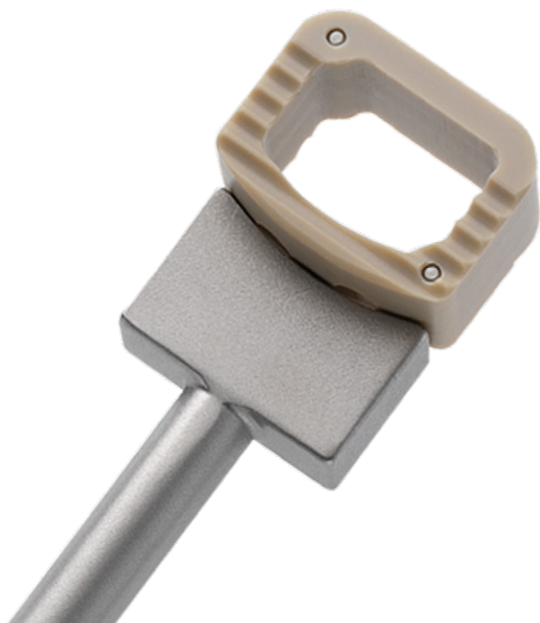

Construx Mini PTC Implant Set Part# 37-7000

Part #	Description	Graft Vol. (cc)
37-3006SP	12mm W x 12mm L, 5° Lordotic - 6mm H	0.28
37-3007SP	12mm W x 12mm L, 5° Lordotic - 7mm H	0.33
37-3008SP	12mm W x 12mm L, 5° Lordotic - 8mm H	0.37
37-3009SP	12mm W x 12mm L, 5° Lordotic - 9mm H	0.43
37-3010SP	12mm W x 12mm L, 5° Lordotic - 10mm H	0.48
37-3011SP	12mm W x 12mm L, 5° Lordotic - 11mm H	0.52
37-3012SP	12mm W x 12mm L, 5° Lordotic - 12mm H	0.57

37-3106SP	12mm W x 12mm L, Parallel - 6mm H	0.31
37-3107SP	12mm W x 12mm L, Parallel - 7mm H	0.35
37-3108SP	12mm W x 12mm L, Parallel - 8mm H	0.40
37-3109SP	12mm W x 12mm L, Parallel - 9mm H	0.45
37-3110SP	12mm W x 12mm L, Parallel - 10mm H	0.50
37-3111SP	12mm W x 12mm L, Parallel - 11mm H	0.55
37-3112SP	12mm W x 12mm L, Parallel - 12mm H	0.60

37-4006SP	15mm W x 12mm L, 5° Lordotic - 6mm H	0.39
37-4007SP	15mm W x 12mm L, 5° Lordotic - 7mm H	0.46
37-4008SP	15mm W x 12mm L, 5° Lordotic - 8mm H	0.53
37-4009SP	15mm W x 12mm L, 5° Lordotic - 9mm H	0.60
37-4010SP	15mm W x 12mm L, 5° Lordotic - 10mm H	0.67
37-4011SP	15mm W x 12mm L, 5° Lordotic - 11mm H	0.74
37-4012SP	15mm W x 12mm L, 5° Lordotic - 12mm H	0.81

Construx Mini PTC Implant Set Part# 37-7000

Part #	Description	Graft Vol. (cc)
37-4106SP	15mm W x 12mm L, Parallel - 6mm H	0.43
37-4107SP	15mm W x 12mm L, Parallel - 7mm H	0.50
37-4108SP	15mm W x 12mm L, Parallel - 8mm H	0.57
37-4109SP	15mm W x 12mm L, Parallel - 9mm H	0.64
37-4110SP	15mm W x 12mm L, Parallel - 10mm H	0.71
37-4111SP	15mm W x 12mm L, Parallel - 11mm H	0.77
37-4112SP	15mm W x 12mm L, Parallel - 12mm H	0.85

37-5006SP	15mm W x 15mm L, 5° Lordotic - 6mm H	0.55
37-5007SP	15mm W x 15mm L, 5° Lordotic - 7mm H	0.65
37-5008SP	15mm W x 15mm L, 5° Lordotic - 8mm H	0.75
37-5009SP	15mm W x 15mm L, 5° Lordotic - 9mm H	0.84
37-5010SP	15mm W x 15mm L, 5° Lordotic - 10mm H	0.94
37-5011SP	15mm W x 15mm L, 5° Lordotic - 11mm H	1.04
37-5012SP	15mm W x 15mm L, 5° Lordotic - 12mm H	1.14



Modular Trials Caddy (OPTIONAL) Part# 47-9117

Part #	Description
47-1005	12mm W x 12mm L, 5° Lordotic - 5mm H
47-1006	12mm W x 12mm L, 5° Lordotic - 6mm H
47-1007	12mm W x 12mm L, 5° Lordotic - 7mm H
47-1008	12mm W x 12mm L, 5° Lordotic - 8mm H
47-1009	12mm W x 12mm L, 5° Lordotic - 9mm H
47-1010	12mm W x 12mm L, 5° Lordotic - 10mm H
47-1011	12mm W x 12mm L, 5° Lordotic - 11mm H
47-1012	12mm W x 12mm L, 5° Lordotic - 12mm H
47-1013	12mm W x 12mm L, 5° Lordotic - 13mm H
47-1014	12mm W x 12mm L, 5° Lordotic - 14mm H
47-1105	12mm W x 12mm L, Parallel - 5mm H
47-1106	12mm W x 12mm L, Parallel - 6mm H
47-1107	12mm W x 12mm L, Parallel - 7mm H
47-1108	12mm W x 12mm L, Parallel - 8mm H
47-1109	12mm W x 12mm L, Parallel - 9mm H
47-1110	12mm W x 12mm L, Parallel - 10mm H
47-1111	12mm W x 12mm L, Parallel - 11mm H
47-1112	12mm W x 12mm L, Parallel - 12mm H
47-1113	12mm W x 12mm L, Parallel - 13mm H
47-1114	12mm W x 12mm L, Parallel - 14mm H
47-2005	15mm W x 12mm L, 5° Lordotic - 5mm H
47-2006	15mm W x 12mm L, 5° Lordotic - 6mm H
47-2007	15mm W x 12mm L, 5° Lordotic - 7mm H
47-2008	15mm W x 12mm L, 5° Lordotic - 8mm H
47-2009	15mm W x 12mm L, 5° Lordotic - 9mm H
47-2010	15mm W x 12mm L, 5° Lordotic - 10mm H
47-2011	15mm W x 12mm L, 5° Lordotic - 11mm H
47-2012	15mm W x 12mm L, 5° Lordotic - 12mm H
47-2013	15mm W x 12mm L, 5° Lordotic - 13mm H
47-2014	15mm W x 12mm L, 5° Lordotic - 14mm H
47-2105	15mm W x 12mm L, Parallel - 5mm H
47-2106	15mm W x 12mm L, Parallel - 6mm H
47-2107	15mm W x 12mm L, Parallel - 7mm H
47-2108	15mm W x 12mm L, Parallel - 8mm H
47-2109	15mm W x 12mm L, Parallel - 9mm H
47-2110	15mm W x 12mm L, Parallel - 10mm H
47-2111	15mm W x 12mm L, Parallel - 11mm H
47-2112	15mm W x 12mm L, Parallel - 12mm H
47-2113	15mm W x 12mm L, Parallel - 13mm H
47-2114	15mm W x 12mm L, Parallel - 14mm H
37-5806	15mm W x 15mm L, 5° Lordotic - 6mm H
37-5807	15mm W x 15mm L, 5° Lordotic - 7mm H
37-5808	15mm W x 15mm L, 5° Lordotic - 8mm H
37-5809	15mm W x 15mm L, 5° Lordotic - 9mm H
37-5810	15mm W x 15mm L, 5° Lordotic - 10mm H
37-5906	15mm W x 15mm L, Parallel - 6mm H
37-5907	15mm W x 15mm L, Parallel - 7mm H
37-5908	15mm W x 15mm L, Parallel - 8mm H
37-5909	15mm W x 15mm L, Parallel - 9mm H
37-5910	15mm W x 15mm L, Parallel - 10mm H

Double Ended Trials

Part #	Description
47-6006	12mm W x 12mm L, 5° Lordotic - 6/7mm H
47-6008	12mm W x 12mm L, 5° Lordotic - 8/9mm H
47-6010	12mm W x 12mm L, 5° Lordotic - 10/11mm H
47-6012	12mm W x 12mm L, 5° Lordotic - 12/13mm H
47-6206	15mm W x 12mm L, 5° Lordotic - 6/7mm H
47-6208	15mm W x 12mm L, 5° Lordotic - 8/9mm H
47-6210	15mm W x 12mm L, 5° Lordotic - 10/11mm H
47-6212	15mm W x 12mm L, 5° Lordotic - 12/13mm H
47-6406	15mm W x 15mm L, 5° Lordotic - 6/7mm H
47-6408	15mm W x 15mm L, 5° Lordotic - 8/9mm H
47-6410	15mm W x 15mm L, 5° Lordotic - 10/11mm H
47-6412	15mm W x 15mm L, 5° Lordotic - 12/13mm H

Rasps

Part #	Description
47-9306	12mm W x 12mm L, 5° Lordotic - 6mm H
47-9307	12mm W x 12mm L, 5° Lordotic - 7mm H
47-9308	12mm W x 12mm L, 5° Lordotic - 8mm H
47-9309	12mm W x 12mm L, 5° Lordotic - 9mm H
47-9506	15mm W x 12mm L, 5° Lordotic - 6mm H
47-9507	15mm W x 12mm L, 5° Lordotic - 7mm H
47-9508	15mm W x 12mm L, 5° Lordotic - 8mm H
47-9509	15mm W x 12mm L, 5° Lordotic - 9mm H

Instruments, Cases and Trays

Part #	Description
30-1030	Impactor
47-1020	Trial Handle, CONSTRUX Mini
47-1040	Implant Inserter, CONSTRUX Mini
47-1050	Packing Tool, CONSTRUX Mini
37-7000	PTC Implant Set
37-8000	PTC Carrying Case
47-9000	Instrument Case
47-9001	Top Level Tray
47-9002	Bottom Level Tray
47-9003	12mm W x 12mm D, Parallel Construx Mini PEEK Implant Caddy
47-9004	15mm W x 12mm D, Parallel Construx Mini PEEK Implant Caddy
47-9005	12mm W x 12mm D, Lordotic Construx Mini PEEK Implant Caddy
47-9006	15mm W x 12mm D, Lordotic Construx Mini PEEK Implant Caddy
47-9007	Modular Trials Caddy

*Items in blue available upon request only.

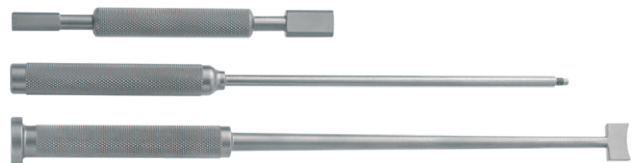

Please visit [Orthofix.com/IFU](https://www.orthofix.com/IFU) for full information on indications for use, contraindications, warnings, precautions, adverse reactions and sterilization.

Caution: Federal law (USA) restricts this device to sale by or on the order of a physician. Proper surgical procedure is the responsibility of the medical professional. Operative techniques are furnished as an informative guideline. Each surgeon must evaluate the appropriateness of a technique based on his or her personal medical credentials and experience.



Orthofix
3451 Plano Parkway
Lewisville, Texas 75056-9453 USA
1.214.937.3199
1.888.298.5700
www.orthofix.com



Medical Device Safety Services (MDSS):
Schiffgraben 41
30175, Hannover
Germany
+49 511 6262 8630
www.mdss.com

Rx Only
CE ²⁷⁹⁷

Orthofix products or services referenced herein are trademarks or registered trademarks of Orthofix Medical Inc. and its group of companies. Any rights not expressly granted herein are reserved.