

The XCaliber Bone Screws

Insertion Technique

20

XCALIBER BONE SCREWS

XCaliber Bone Screws are suitable for use in both cancellous and cortical bone. They are supplied in two different lengths, 150 mm and 260 mm, and are cut to the appropriate length before or after insertion. Each screw length is supplied with 7 different thread lengths, in 10 mm steps from 30 mm to 90 mm.

The different screw sizes are shown in the table below. All screws are available in uncoated or Hydroxyapatite coated (Osteotite) versions.



XCaliber Bone Screws*							
	Thread length (mm)						
Total length	30	40	50	60	70	80	90
150 mm	911530	911540	911550	911560	911570	911580	911590
260 mm	912630	912640	912650	912660	912670	912680	912690

* XCaliber Bone Screws are also available packaged sterile. They can be ordered using the above code numbers preceded by 99- (e.g. 99-911530).

XCaliber Osteotite Bone Screws							
	Thread length (mm)						
Total length	30	40	50	60	70	80	90
150 mm	99-611530	99-611540	99-611550	99-611560	99-611570	99-611580	99-611590
260 mm	99-612630	99-612640	99-612650	99-612660	99-612670	99-612680	99-612690

EQUIPMENT REQUIRED

91101	Bone Screw Cutter
91120	Hand Drill
91125	Ruler
91150	XCaliber Universal T-Wrench
91140	XCaliber Bone Screw Rack (for sterile screws)
450135	XCaliber Screw Tray (empty)

Standard Instrumentation for Screw Insertion

STERILE	R
----------------	----------

CAUTION: Federal (U.S.A.) law restricts this device to sale by or on the order of a physician. Contents sterile unless package opened or damaged; Do not use if package is opened or damaged.

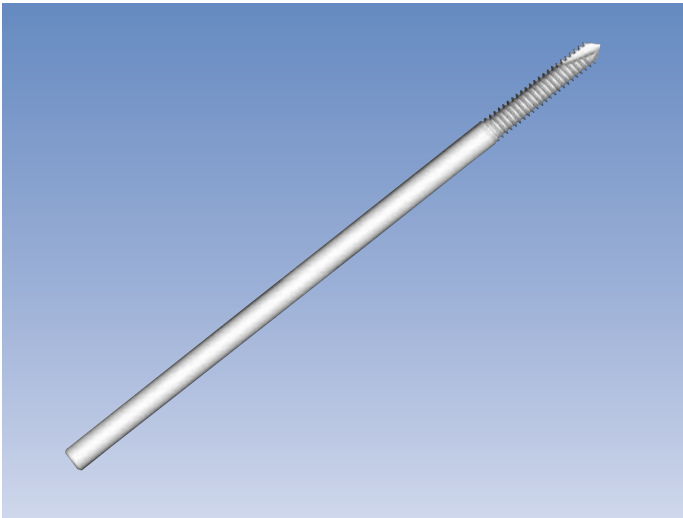

- The screw thread tapers from 6.0 mm to 5.6 mm diameter. The taper has been designed to provide a radial preload during insertion to maintain good fixation in the first cortex, which is so important for monolateral external fixation. The amount of taper has been set at this level to allow for limited backing out of the bone screws after insertion without significant screw loosening. The inherent elasticity of the bone permits this. However, **the screws should not be backed out for more than two full turns**, because larger amounts might cause loosening.

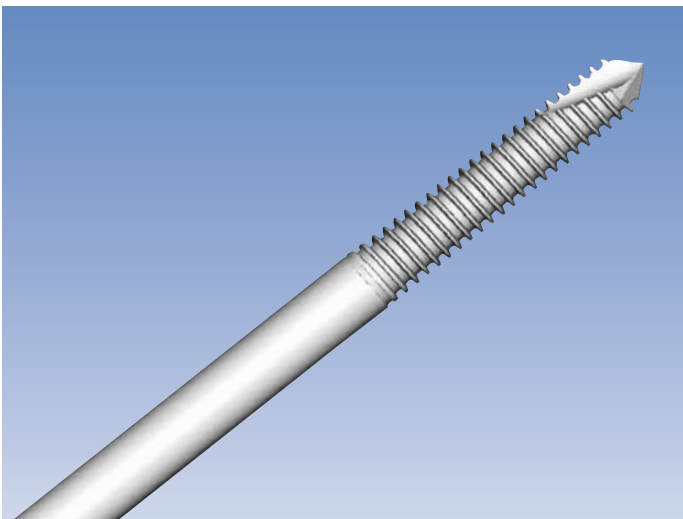

- The screws all have a pointed tip and flute which allow them to be inserted self-drilling, without pre-drilling, in most situations, whether uncoated or HA coated, and direct insertion with a hand drill is advised in most cases. However, when insertion of self-drilling screws is performed in diaphyseal bone, pre-drilling is recommended; use a 4.8 mm drill bit through a drill guide when the bone is hard; when the bone quality is poor, or in the metaphyseal region where the cortex is thin, a 3.2 mm drill bit should be used.

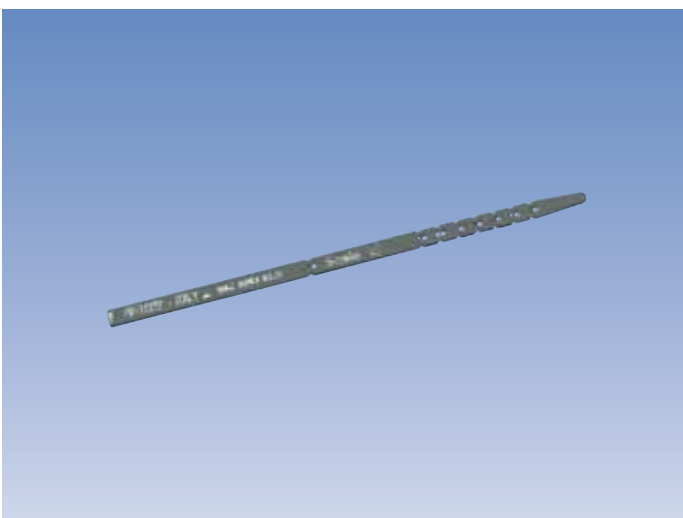

SELECTION OF THE CORRECT SCREW THREAD AND SHAFT LENGTH

Use of the Ruler

- XCaliber bone screws can be used in any situation where the diameter of the bone at the point of insertion is greater than 20 mm. If it is less than 20 mm, smaller diameter screws should be used. Care should be taken that the screw is inserted in the centre of the bone axis. If it is too peripheral the bone may be weakened. The metal ruler can be used to determine the correct screw thread length. It can be used against the X-ray or directly on the limb. The latter option is preferred, as the magnification of an X-ray film may be uncertain, and the exact screw position may not be defined well enough where the bone is tapering, for example in the proximal tibia. The correct thread length can be read directly from the Image Intensifier screen, if the ruler is held over the limb in the proposed screw position.

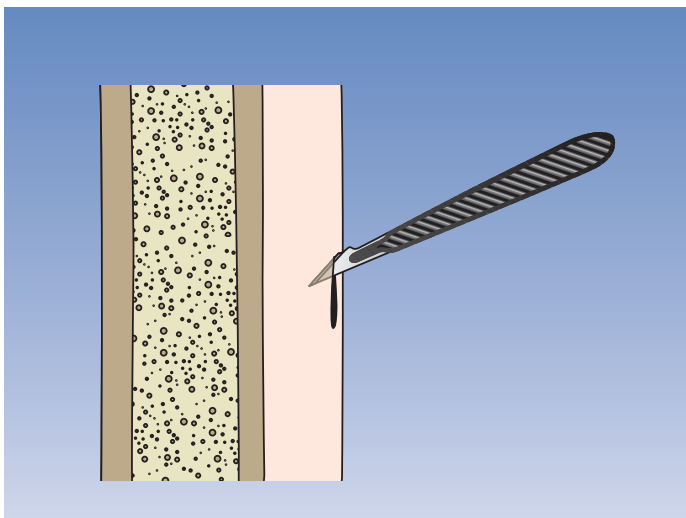

Screw Insertion

- Make a 15-20 mm incision so that the skin around each screw is not too tight. The underlying tissues also require broad blunt dissection down to the bone.

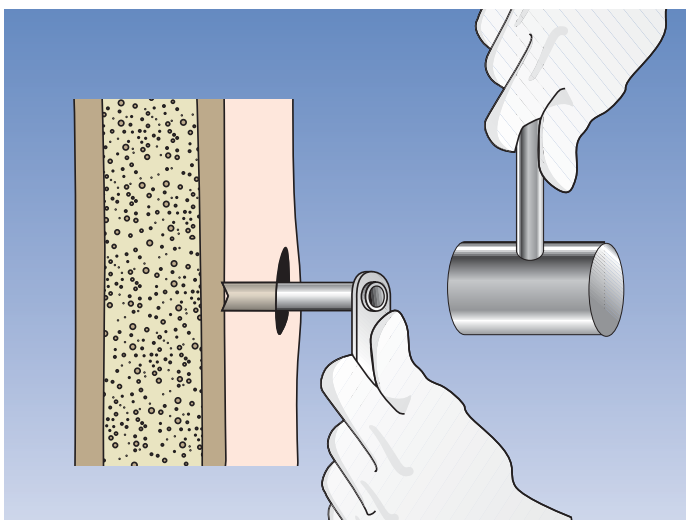

- Insert a screw guide perpendicular to the longitudinal axis of the bone. Use a trocar to locate the midline by palpation. Keep the screw guide in contact with the cortex by gentle pressure, withdraw the trocar, and tap the screw guide lightly to anchor its distal end.

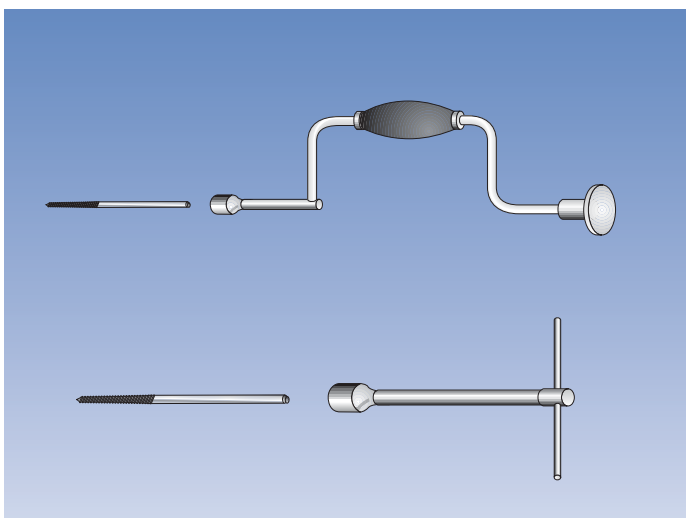

When Inserted Self-Drilling

- **Xcaliber bone screws should never be inserted with a power tool.** This may result in too high an insertion speed being used, which causes high temperatures and cell necrosis. Screw insertion, whether or not pre-drilling has been performed, should always be with the XCaliber Hand Drill or T-Wrench only. It is important that moderate force is applied for the screw to gain entry into the first cortex. The screws have a round shank. They are inserted with the XCaliber T-Wrench or Hand Drill which pushes over and grips the shank securely, and are extracted in the same way.

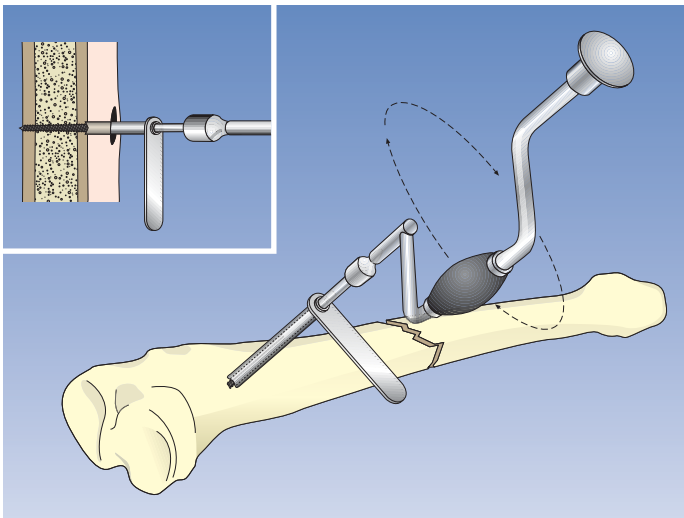

- Insert a screw through the screw guide into the bone using the hand drill. While drilling, the hand drill should be held steady so that the drilling direction is maintained throughout the procedure. Once the second cortex has been reached, reduce the drilling speed; four more turns are needed so that the tip just protrudes through the distal cortex. In cancellous bone, there is no need for the tip of the screw to protrude from the second cortex. Diaphyseal bone screws should always be inserted in the centre of the bone axis, to avoid weakening it. In all cases the surgeon should be mindful of the amount of torque required to insert the screw. If it seems tighter than usual, it is safer to remove the screw and clean it, and drill the hole again with a 4.8 mm drill bit, even if it has already been used.

Note: Self-drilling screws with a thread diameter smaller than 5 mm can be inserted by hand or with a power drill at low speed.

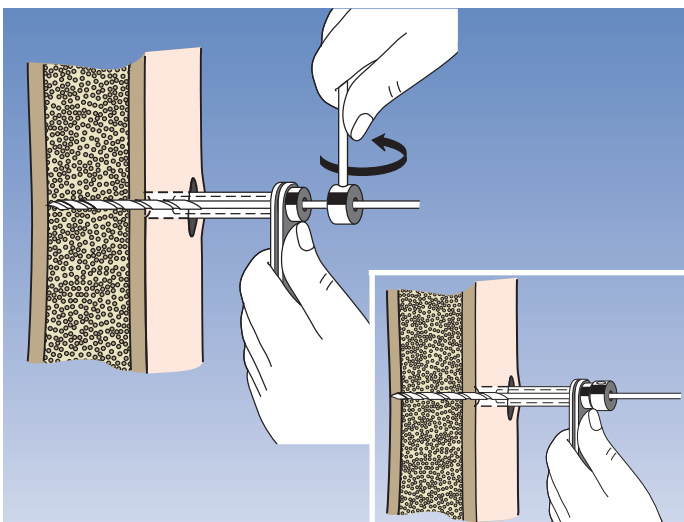

When Inserted After Pre-Drilling

- Insert the 3.2 mm or 4.8 mm drill guide into the screw guide, and introduce a 3.2 mm or 4.8 mm drill bit. Drill at 500-600 rpm through the first cortex, checking that the drill bit is at right angles to the bone. The force applied to the drill should be firm and the drilling time as short as possible to avoid thermal damage. Stop at the second cortex, offset the stop collar on the drill bit by 5 mm, and continue through the bone. Ensure that the drill bit completely penetrates the second cortex.

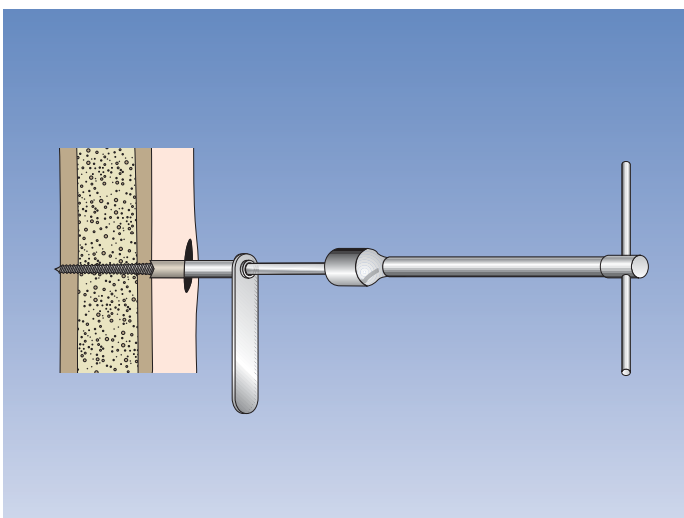

- Remove the drill bit and drill guide, keeping pressure on the handle of the screw guide. The screw is inserted with the T-Wrench or hand drill until it reaches the second cortex. A further 4 turns are required to ensure that about 2 mm of the screw protrudes beyond the second cortex.

Warning! As the thread is tapered, repositioning the screw by turning counterclockwise more than two turns will loosen the bone-screw interface.

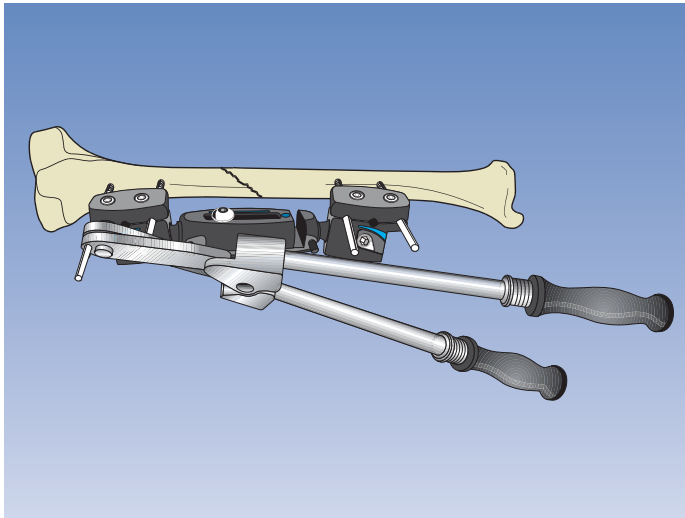

CUTTING THE BONE SCREW SHAFTS TO LENGTH

- When all screws have been inserted and the screw guides removed the fixator is applied. After the fixator clamps have been securely locked over the screws, the screw shafts can be cut with the bone screw cutter. Although the screws can be cut before insertion, it is difficult to gauge the length accurately, and it is recommended that they are cut after the fixator has been applied. It is important that all of the screws are inserted first, and the fixator applied with the clamps tightened firmly over the screws, about 20 mm from the skin. The cutter can then be slid over the screw shanks in turn and the screws cut close to the fixator clamps. This will normally result in about 6 mm of screw shank protruding from the fixator. The cutter is designed so that it can be used even when screws are in adjacent seats in the clamp. The cut ends of the screws can then be protected with screw caps. When cutting the screws, the arms of the cutter should be extended for greater efficiency, and the outer end of the screw held to prevent it causing injury.

The Orthofix Quality System has been certified to be in compliance with the requirements of:

- Medical Devices Directive 93/42/EEC, Annex II - (Full Quality System)
- International Standards ISO 13485 / ISO 9001 for external fixator devices, implants for osteosynthesis and related instruments.



See "Orthofix External Fixation System" instruction leaflet (PQ EXF) prior to use.

Orthofix wishes to thank

V. Caiaffa, MD

Institute of Clinical Orthopaedics and Traumatology,
University of Bari, Bari, Italy

M. Manca, MD

Orthopaedic Department, "Della Versilia" Hospital,
Viareggio, Italy

D. Pennig, Prof., MD

Department of Trauma, Hand and Reconstructive Surgery
St. Vinzenz-Hospital, Köln, Germany

A. Sancin, MD

Orthopaedic Department, Massa Hospital, Massa, Italy
Ospedale di Massa, Italy

**for their invaluable help in the preparation
of this Quick Reference Guide and their contribution to the design
and refinement of the equipment described**

Manufactured by: ORTHOFIX Srl.
Via Delle Nazioni 9
37012 Bussolengo (Verona)
Italy

Telephone 0039-0456719000
Fax 0039-0456719380



Your Distributor is:

XC-0404-OR-E0

Adult & Pediatric Deformity Correction | Fixation | Bone Growth Stimulation | Foot & Ankle