



GALAXY FIXATION™ SYSTEM UPPER EXTREMITIES

INTRODUCTION	1
INDICATIONS	1
FEATURES AND BENEFITS	2
EQUIPMENT REQUIRED	11
HUMERAL APPLICATION	15
MULTI-SCREW CLAMPS	20
SHOULDER APPLICATION	21
ELBOW APPLICATION	22
ELBOW DISTRACTOR UNIT	30
WRIST APPLICATION	36
UPPER LIMB APPLICATIONS	52
MRI INFORMATION	53

INTRODUCTION

External fixators have become multi-function devices with indications for use in trauma and Orthopaedics. It is used for damage control or definitive treatment of injuries whereas Orthopaedic applications have included reconstructive surgery. The Galaxy Fixation™ system is designed to provide the multi-function capabilities of an external fixator for modern trauma and reconstructive surgery. The components have been designed for rapid application, stability and ease of use. The modules of the Galaxy Fixation™ system have a consistency of design across the range of trauma and reconstructive modules. This ensures that surgeons can become accustomed to the entire range quickly. Additionally, the system encompasses the facility for use in small and large long bones and thus extends to cover adult and paediatric applications. This wide capability has been designed with stability being a primary system characteristic.

In so doing, the surgeon can:

- place screws where the condition of the bone and soft tissues permits
- reduce the fracture or joint in order to restore alignment easily
- achieve stability with the efficient use of bone screws, rods and clamps (examples of fixator configurations which provide stability through optimal use components are provided and thereby contribute to standardisation of use).

Hinged modules (i.e. Elbow Hinge and Wrist Module) are available in the Galaxy Fixation™ system. These Hinged Modules allow alignment with the rotational centre of the joint, thus permitting early joint mobilisation.

INDICATIONS

The Galaxy Fixation™ System is intended to be used for bone stabilization in trauma and orthopedic procedures, both on adults and all pediatric subgroups excepts newborns as required.

The indications for use include:

- open or closed fractures of the long bones;
- vertically stable pelvic fractures or as a treatment adjunct for vertically unstable pelvic fractures;
- infected and aseptic non-unions;
- joint pathologies/injuries of upper and lower limb, such as:
 - proximal humeral fractures;
 - intra-articular knee, ankle and wrist fractures;
 - delayed treatment of dislocated and stiff elbows;
 - chronic, persistent elbow joint instability;
 - acute elbow joint instability after complex ligament injuries;
 - unstable elbow fractures;
 - additional elbow stabilization of post-operative unstable internal fixation.
- The Orthofix Galaxy Wrist external fixator is intended for the following indications:
 - intra-articular or extra-articular fractures and dislocations of the wrist with or without soft tissue damage
 - polytrauma
 - carpal dislocations
 - unreduced fractures following conservative treatment
 - bone-loss or other reconstructive procedures
 - infection

NOTE: The Shoulder Fixation System is intended to be used for proximal humeral fractures where two thirds of the metaphysis is intact.

For MRI Information see page 53.

The rods and bone screws are strictly single patient use.

FEATURES AND BENEFITS

Rods

Strong radiolucent rods in three different diameters (12mm for Lower Limb, 9 and 6mm for Upper Limb) and various lengths.



Code	Description
932100	Rod 100mm long
932150	Rod 150mm long
932200	Rod 200mm long
932250	Rod 250mm long
932300	Rod 300mm long
932350	Rod 350mm long
932400	Rod 400mm long
99-932450	Rod 450mm long, sterile*
99-932500	Rod 500mm long, sterile*
99-932550	Rod 550mm long, sterile*
99-932600	Rod 600mm long, sterile*
99-932650	Rod 650mm long, sterile*

* Special order only



Code	Description
939100	Rod 100mm long
939150	Rod 150mm long
939200	Rod 200mm long
939250	Rod 250mm long
939300	Rod 300mm long



Code	Description
936060	Rod 60mm long
936080	Rod 80mm long
936100	Rod 100mm long
936120	Rod 120mm long
936140	Rod 140mm long
936150	Rod 150mm long
936160	Rod 160mm long
936180	Rod 180mm long
936200	Rod 200mm long



Code	Description
936010	6mm L Rod

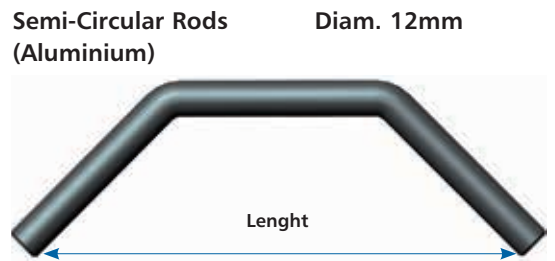

Code	Description
932010	Semi-Circular Rod small 180mm long
932020	Semi-Circular Rod medium 215mm long
932030	Semi-Circular Rod large 250mm long

Semi-Circular Rods **Diam. 9mm**

939010	Semi-Circular Rod small 115mm long
939020	Semi-Circular Rod medium 140mm long
939030	Semi-circular Rod large 165mm long

All rods are also available single-packed and sterile. They can be ordered using the above code numbers preceded by 99- (e.g. 99-932100)

Screws

XCaliber Bone Screws Shaft Ø 6mm- Thread Ø 6.0-5.6mm

Code	Total L	Thread L	Code	Total L	Thread L
912630	260	30	911530	150	30
912640	260	40	911540	150	40
912650	260	50	911550	150	50
912660	260	60	911560	150	60
912670	260	70	911570	150	70
912680	260	80	911580	150	80
912690	260	90	911590	150	90

- Drill bit Ø 4.8mm when the bone is hard
- Drill bit Ø 3.2mm in poor quality bone or in the metaphyseal region

Bone Screws Shaft Ø 6mm - Thread Ø 4.5-3.5mm

Code	Total L	Thread L	Code	Total L	Thread L
10190	70	20	10105	100	40
10191	80	20	10137	120	20
10108	80	30	10138	120	30
10135	100	20	10106	120	40
10136	100	30			

- Drill bit Ø 3.2mm

Bone Screws Shaft Ø 4mm - Thread Ø 3.3-3.0mm

Code	Total L	Thread L	Code	Total L	Thread L
35100	70	20	35101	80	35

- Drill bit Ø 2.7mm

Self-drilling Bone Screws Shaft Ø 4mm - Thread Ø 3.3-3.0mm

Code	Total L	Thread L	Code	Total L	Thread L
37100	60	20	37101	70	30
37102	100	30			

Self-drilling Bone Screws Shaft Ø 3mm - Thread Ø 3.0-2.5mm

Code	Total L	Thread L	Code	Total L	Thread L
M310	50	18	M314	70	20
M311	60	20	M315	70	25
M312	60	25	M316	70	30
M313	60	30	M317	100	30
M321	70	15			

XCaliber Cylindrical Bone Screws

Shaft Ø 4mm - Thread Ø 3.0mm



Code	Total L	Thread L	Code	Total L	Thread L
948320	120	20	947320	100	20
948325	120	25	947325	100	25
948335	120	35			

- Self-drilling

Galaxy Fixation™ System is compatible with all Orthofix Bone Screws with shaft and thread diameters as indicated above. Please refer to the Orthofix Products Catalogue.

Clamps for Independent Screw Placement

Allow easy and stable connection of either a rod and a bone screw or two rods

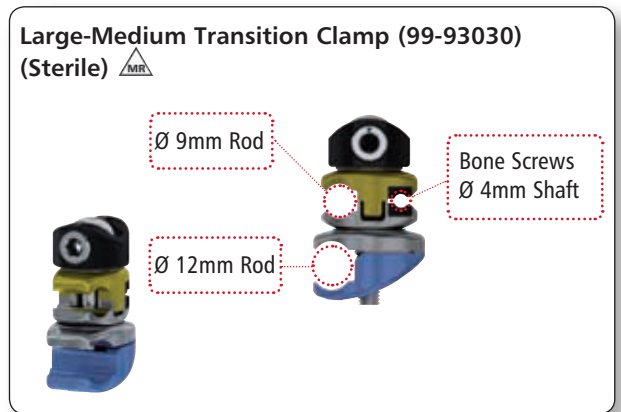
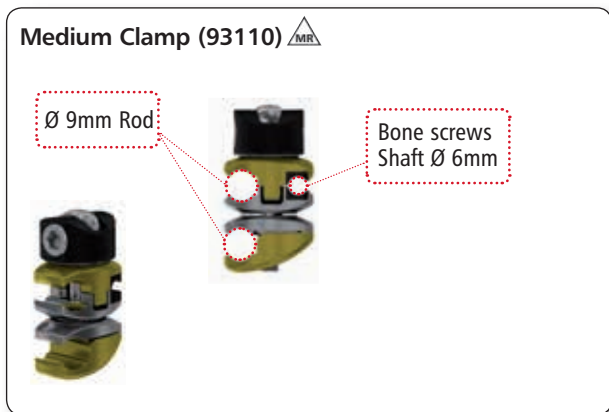
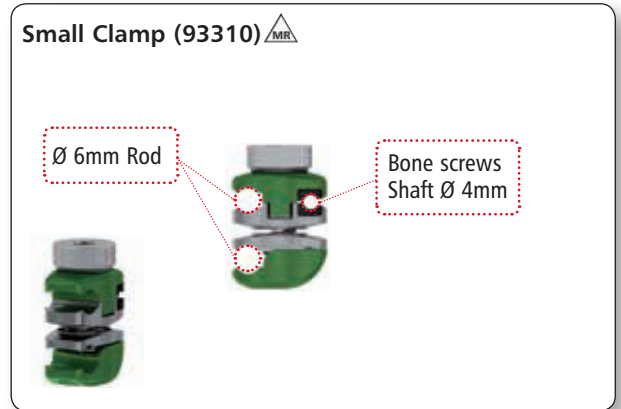
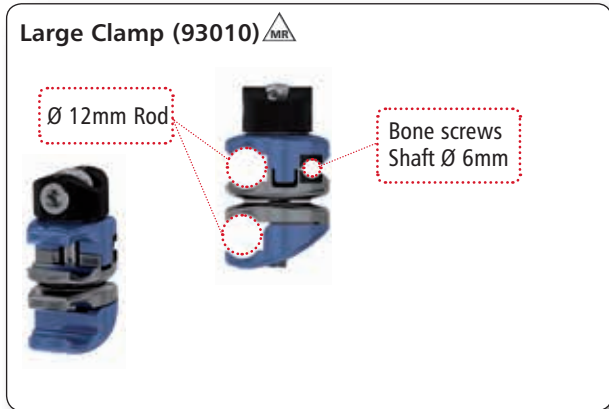

Simple: one clamp for rod-to-rod and pin-to-rod connections

Easy: snap-in system, provisional tightening by hand, definitive cam closure in one step

Versatile: sterile kits for each anatomical site, sterile single-packed components, instrument and implant trays

Stable: internal teeth and locking profiles designed to provide high torsional strength and avoid components sliding

MRI conditional at 1.5 and 3 Tesla

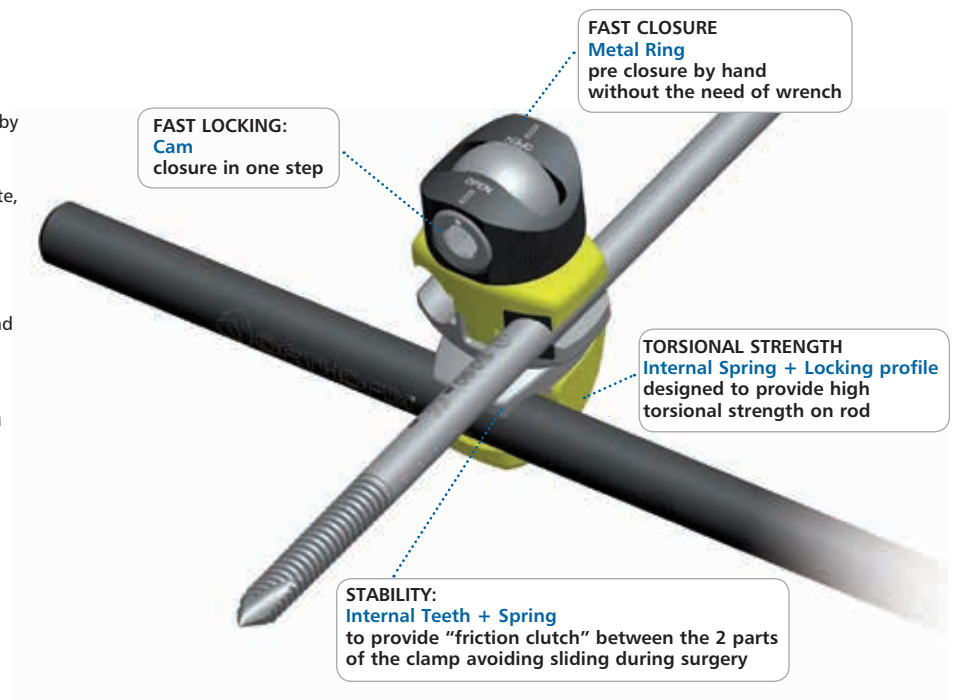

Multi-screw Clamps

Multi-screw Clamp (93020) 

- To be used with 12mm Rod and 6mm shaft bone screws.
- Allows parallel screw positioning either in a T- or a straight clamp configuration.

Note: the positions of the screw holes in the multi-screw clamp refer to the screw seats of the XCaliber fixator or the 1,3,5 screw seats of the LRS fixator T- or straight clamps.

STABILITY:
Internal Spring + Locking profile designed to provide high torsional strength on rod

FAST LOCKING:
Cam closure in one step

FLEXIBILITY OF USE:
Rotation up to +/- 35°

FAST INSERTION:
Snap Lock

FAST CLOSURE:
Metal Ring - pre closure by hand without the need of wrench

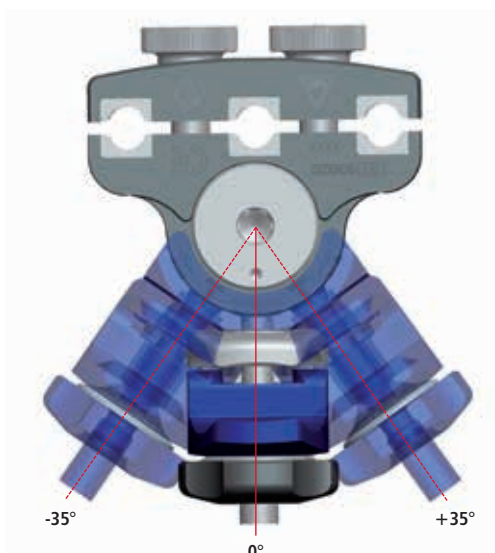

Small Multi-screw Clamp-Long  (93320)

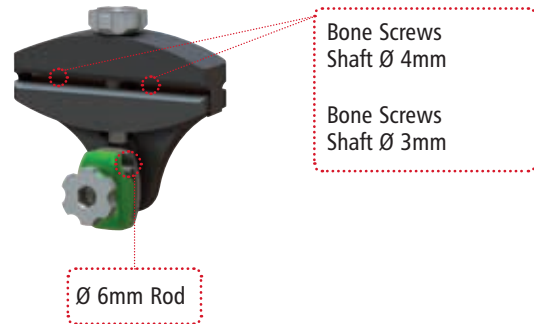

Small Multi-screw Clamp-Short  (93330)

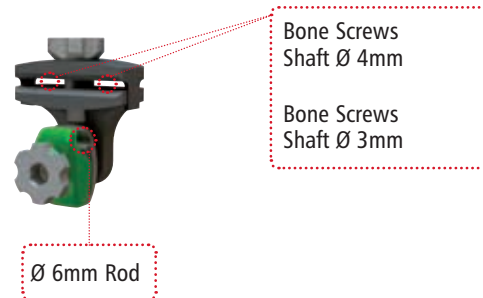

Medium Multi-screw Clamp

(99-93120) (Sterile) 

Allows parallel screw positioning (+/- 35°) in either a T-clamp or straight clamp configuration.

Note: the positions of the screw holes in the medium screw clamp refer to the screw seats of the Small Blue D.A.F. (31000) or the pediatric LRS system (series 55000)



Double Multiscrew Clamps (Sterile)

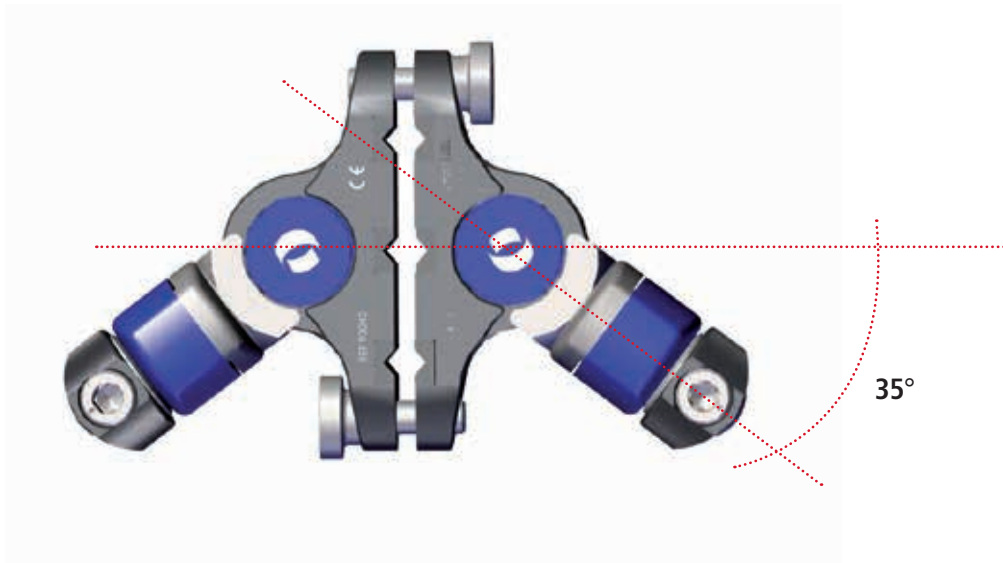
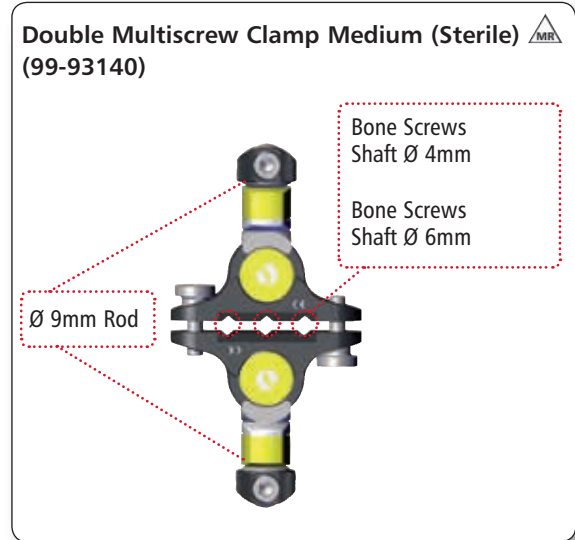
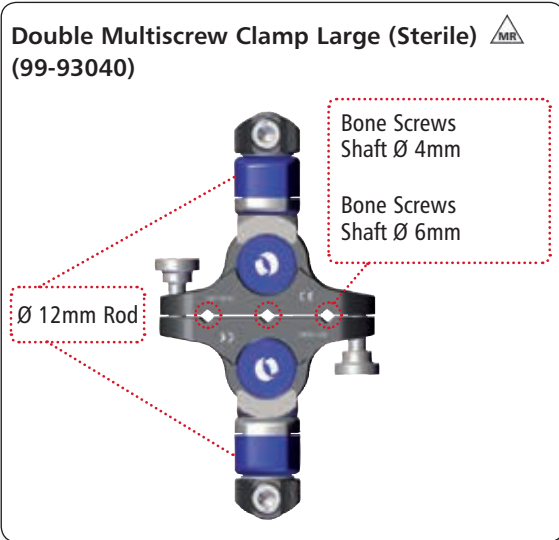

Clamps closure

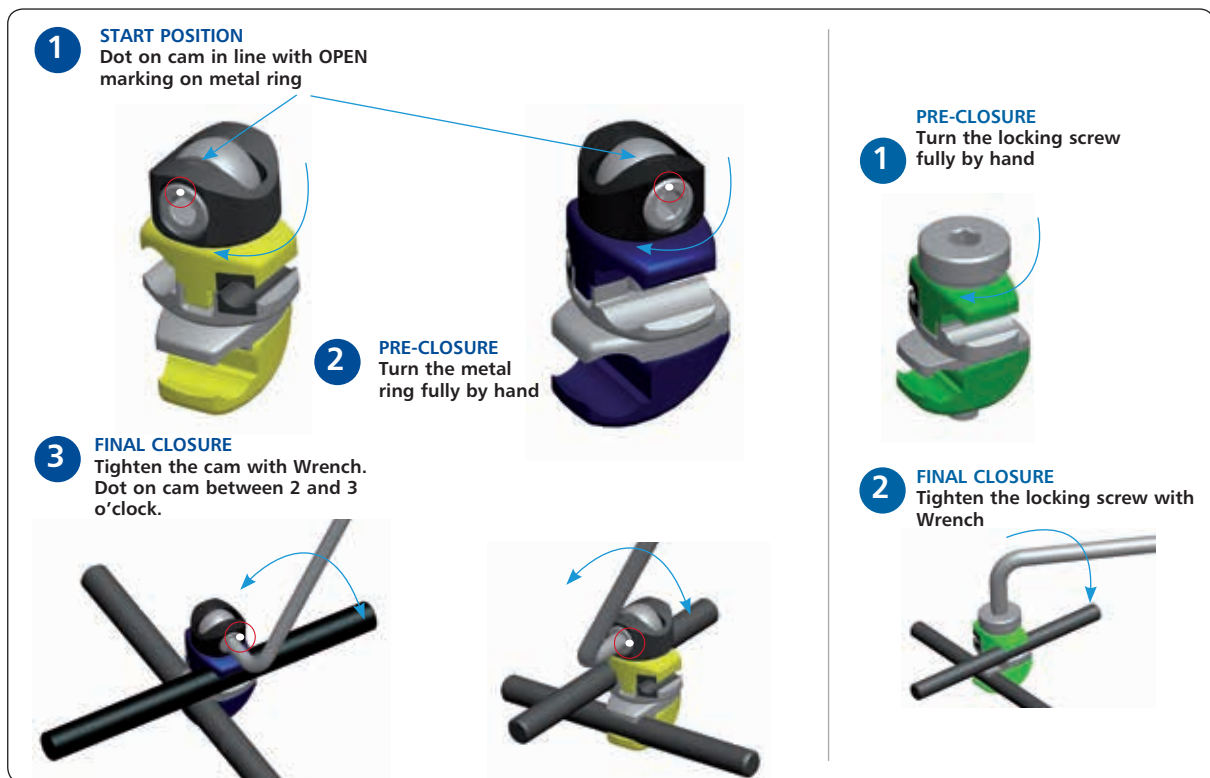

All clamps are also available single-packed and sterile. They can be ordered using the above code numbers preceded by 99- (e.g. 99-93010).

Shoulder Components

Threaded Wire (93100)

It is self-drilling and self-tapping. The wire have been marked at 120 and 165mm to verify the correct insertion depth. Full length of the wire: 300mm, Ø 2.5mm.

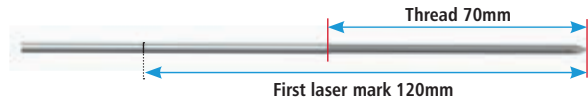

Wire guide (19970)

Allows the correct insertion of the 2.5mm threaded wires.



Wire Targeting Device (19975)

Allows positioning and fixation of the Wire Guides which can be fixed parallel, converging or diverging according to the type of fracture. The Wire Guides must be used to insert the 2.5mm Threaded Wires correctly.

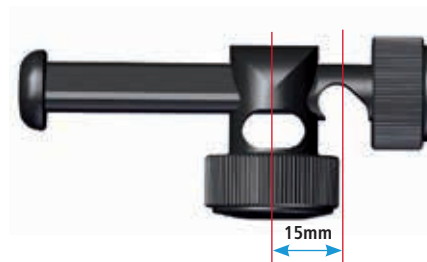
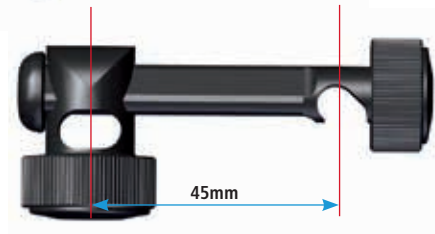
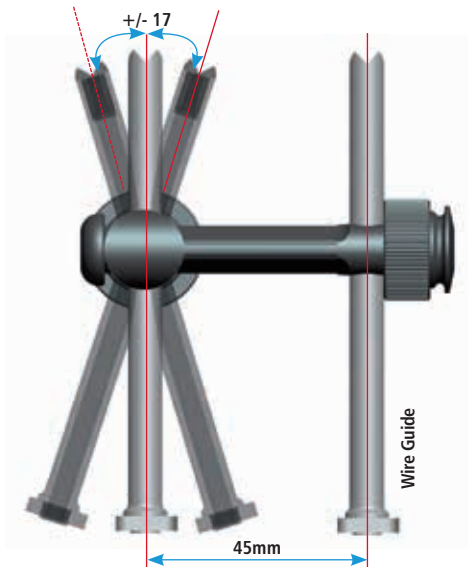

Wire Locking Clamp (93620)

It consists of two disks which lock the 2.5mm Threaded Wire (93100) passing through it (NB: the clamp must not be removed but only slackened).



WARNING: The Threaded Wires (93100) and the Wire Locking Clamps (93620) are not MR Conditional. Any construct/frame that is using Threaded Wires and Wire Locking Clamps must therefore be considered as MR Unsafe (MR).

Elbow Components

Elbow Hinge (93410) 

- To be used with 12mm Rod for the humerus and 9mm Rod for the Ulna
- Radiolucent hinge which allows easy location of the centre of rotation of the elbow, flexion-extension (up to 175°) and micrometric distraction (15mm) of the joint

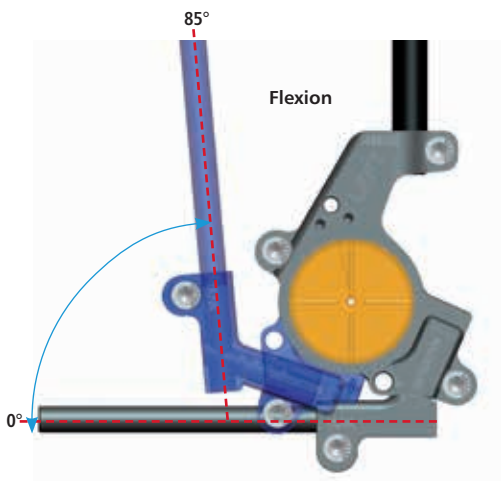
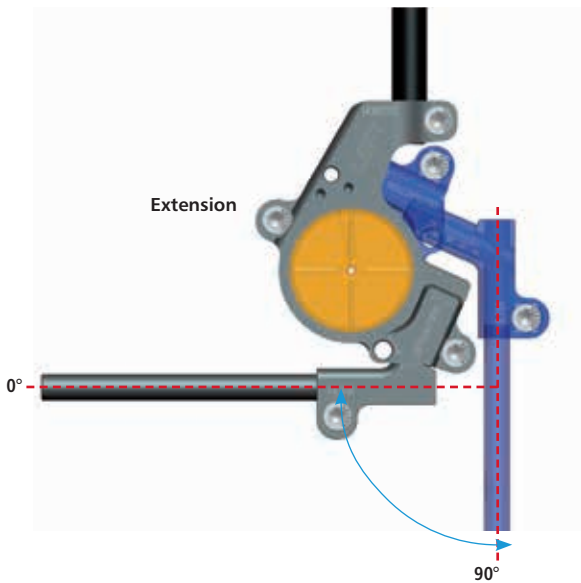
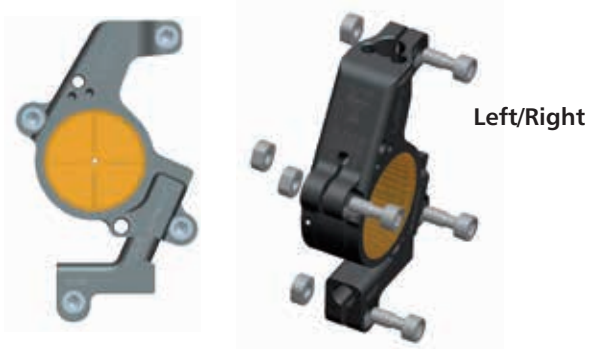

Elbow Distractor (932200 - 93431 - 93432)

- To distract the joint intra-operatively in case of elbow stiffness (see page 34)



Elbow Motion Unit (93420)

- To be used with the Elbow Hinge for passive motion
- Allows controlled, limited flexion/extension of the joint



Wrist Components

Wrist Module (93350) 

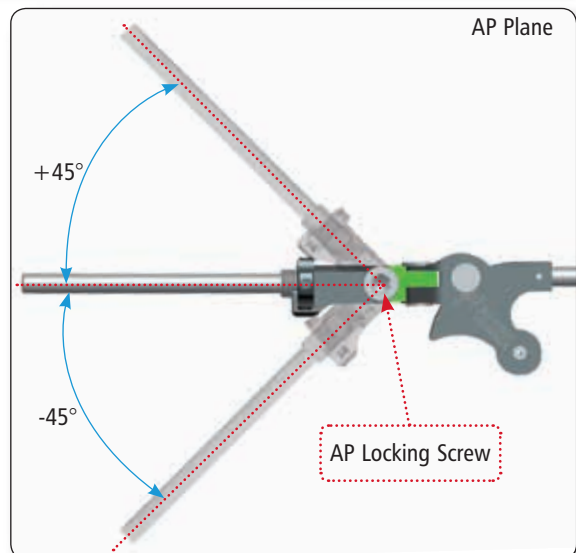
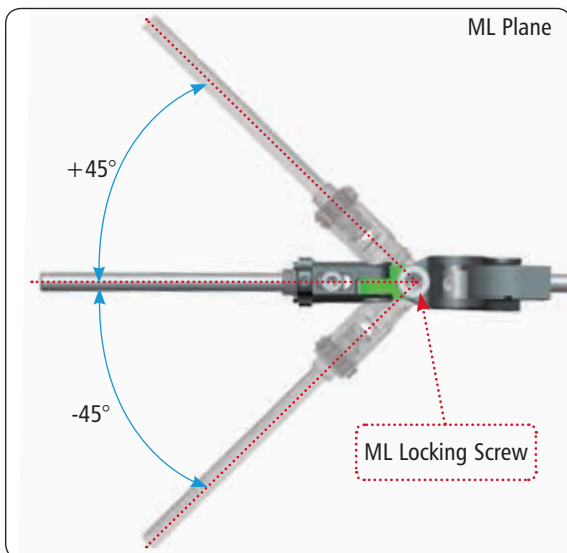
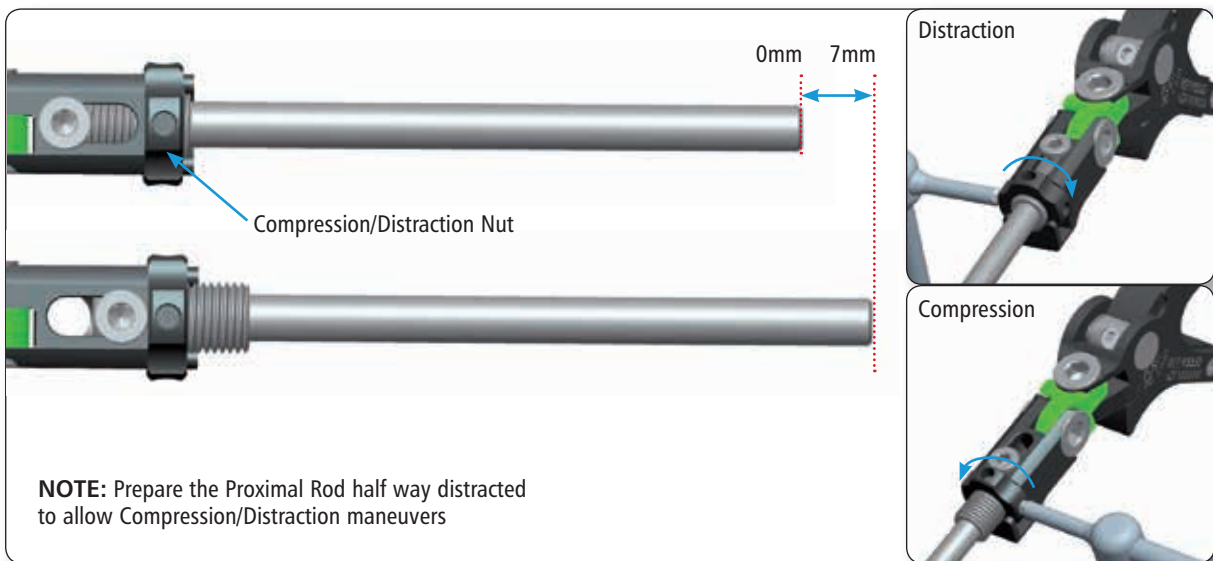
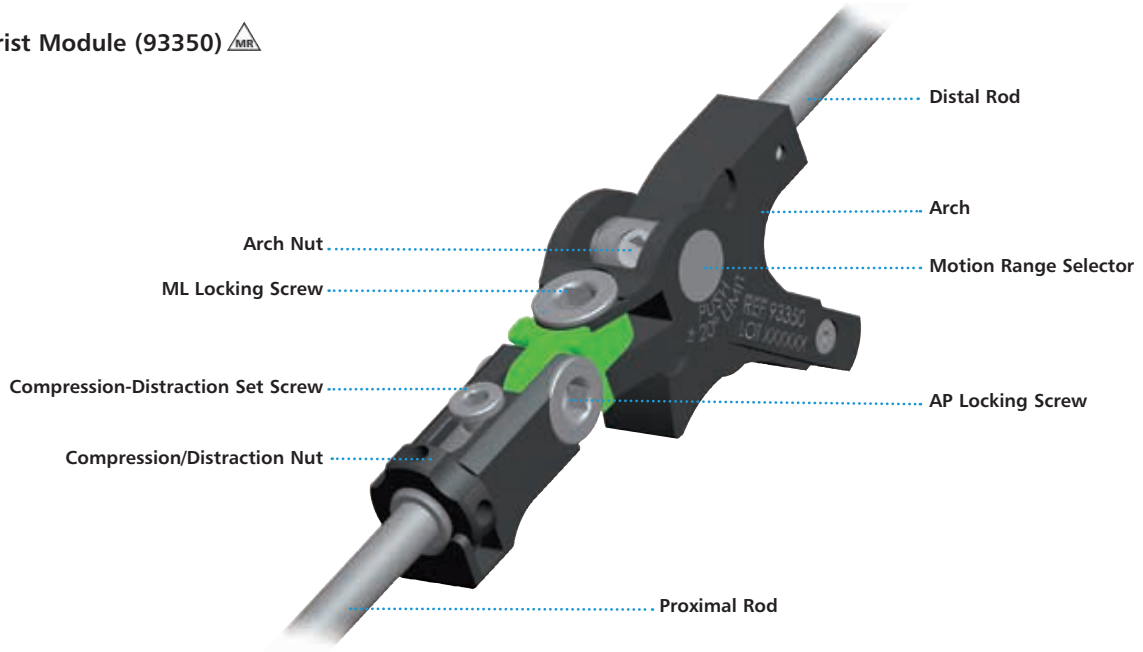

EQUIPMENT REQUIRED

INSTRUMENTS TRAY

Can accommodate:

Code	Description
19940	Multi-screw Clamp Guide
11138	Drill Guide d 4.8mm
11137	Screw Guide 80mm
1-1100201	Drill Bit d 4.8x240mm Coated - Quick Connect
11106	Drill Guide d 3.2mm
11102	Screw Guide 60mm
1-1300301	Drill Bit d 3.2x140mm Coated - Quick Connect
19955	Trocar
19960	Wrist Guide Template with Handle
13530	Drill Guide d 2.7mm
1-1355001	Drill Bit d 2.7x127mm Coated - Quick Connect
19965	Tapered Trocar
M210	T Wrench
93150	Racheting T Handle
93155	Screw Shaft Connection
30017	Allen Wrench 5mm
93017	Wrench 5mm Shaft Connection

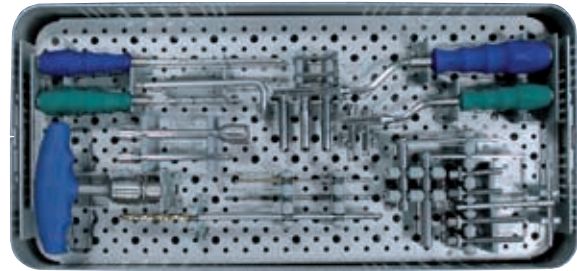

RODS & CLAMPS TRAY*

Can accommodate:

Code	Description
Lower Tray	
93010	Large Clamp
93020	Multi-screw Clamp
932400	Rod d 12mm L 400mm
932350	Rod d 12mm L 350mm
932300	Rod d 12mm L 300mm
932250	Rod d 12mm L 250mm
932200	Rod d 12mm L 200mm
932150	Rod d 12mm L 150mm
932100	Rod d 12mm L 100mm
932030	Semi Circular Rod d 12mm large
932020	Semi Circular Rod d 12mm medium
932010	Semi Circular Rod d 12mm small
Upper Tray	
93110	Medium Clamp
93310	Small Clamp
939300	Rod d 9mm L 300mm
939250	Rod d 9mm L 250mm
939200	Rod d 9mm L 200mm
939150	Rod d 9mm L 150mm
939100	Rod d 9mm L 100mm
936200	Rod d 6mm L 200mm
936180	Rod d 6mm L 180mm
936160	Rod d 6mm L 160mm
936140	Rod d 6mm L 140mm
936120	Rod d 6mm L 120mm
936100	Rod d 6mm L 100mm
936080	Rod d 6mm L 80mm
936060	Rod d 6mm L 60mm

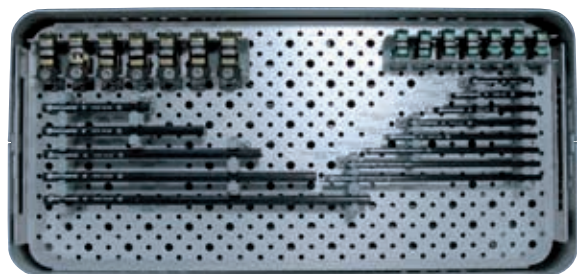
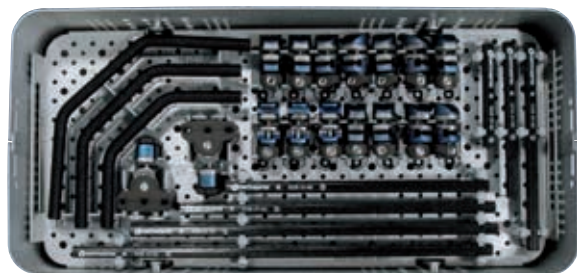

* to order any of the Rods or Clamps, single-packaged and sterile, please add 99- prior to the part number, ex. 99-93010

Out of trays: Large-Medium Transition Clamp 99-93030, Medium Multiscrew Clamp 99-93120, Double Multiscrew Clamp Large 99-93040 and Double Multiscrew Clamp Medium 99-93140

GALAXY SHOULDER TRAY

Can accommodate:

Code	Description
93310	Small Clamp
93620	Wire Locking Clamp
936080	Rod d 6mm L 80mm
936100	Rod d 6mm L 100mm
30017	Allen Wrench 5mm
19975	Wire Targeting Device
19970	Wire Guide
19980	Wire Bender
91150	Bone Screw T Wrench
81031	Open End Wrench

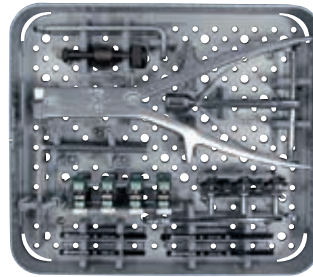

GALAXY ELBOW TRAY

Can accommodate:

Code	Description
Base Tray	
93010	Large Clamp
93020	Multi-screw Clamp
93110	Medium Clamp
93410	Elbow Hinge
932200	Rod d 12mm L 200mm
939150	Rod d 9mm L 150mm
30017	Allen Wrench 5mm
19940	Multi-screw Clamp Guide
1-1100201	Drill Bit d 4.8x240mm Coated - Quick Connect
11138	Drill Guide d 4.8mm
11137	Screw Guide 80mm
11116	Drill Guide d 3.2mm L 80mm
19950	Drill Guide d 3.2mm L 100mm
11102	Screw Guide 60mm
1-1300301	Drill Bit d 3.2x140mm Coated - Quick Connect
1-1100301	Drill Bit d 3.2x200mm Coated - Quick Connect
11146	X-Wire without olive Ø 2mm Length 150mm
19955	Trocar
Insert Tray	
932200	Rod d 12mm L 200mm
93150	Ratcheting T Handle
93155	Screw Shaft Connection
93017	Wrench 5mm Shaft Connection
10017	Allen Wrench 6mm
93440	Wrench 5mm
10025	Torque Wrench 6mm
93431	Humeral Distractor Clamp
93432	Ulnar Distractor Clamp
93420	Elbow Motion Unit

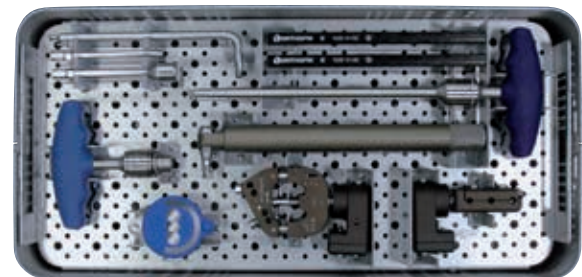
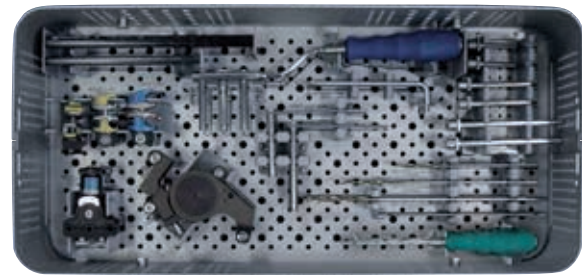

GALAXY WRIST TRAY

Can accommodate:

Code	Description
1x93999	Galaxy Wrist Tray empty
2x93320	Small Multi-screw Clamp-Long
2x93330	Small Multi-screw Clamp-Short
6x93310	Small Clamp
1x93350	Wrist Module
1x936200	Rod d 6mm L 200mm
2x936100	Rod d 6mm L 100mm
1x936080	Rod d 6mm L 80mm
1x936120	Rod d 6mm L 120mm
3x13715	Xwire d 1,5x150mm
1x936010	6mm L Rod
2x19995	Screw Guide
2x13530	Drill Guide d 2.7mm
1x91017	Allen Wrench
2x1-1355001	Drill Bit d 2.7mm
1x19965	Tapered Trocar
1xM210	T Wrench
1x93160	Screw T Wrench QC
1x93175	T Wrench 4mm Shaft

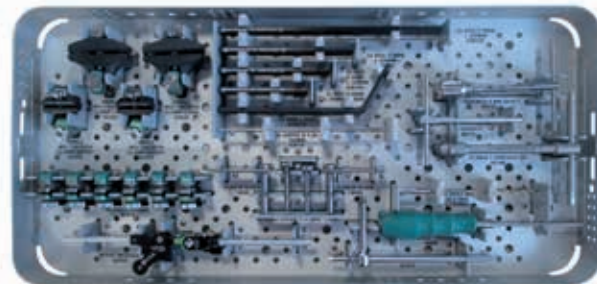

GALAXY WRIST STERILE KIT (99-93601)

Consisting of:

Code	Description
2x93330	Small multi-screw clamp-SHORT
1x93350	Wrist Module
2x19995	Screw Guide
2x13530	Drill guide Ø 2.7mm
1x91017	Allen Wrench
4x947320	Self Drilling XCaliber Cylindrical Screw Shaft Ø 4mm Thread 3mm L 100/20 QC
2x1-1355001	Drill Bit Ø 2,7mm
1x93160	Screw T Wrench QC
3x13715	Kwire Ø 1,5x150mm



GALAXY ELBOW STERILE KIT (99-93504)

Can accommodate:

Code	Description
1x93020	Multi-screw Clamp
2x93110	Medium Clamp
1x93410	Elbow Hinge
1x932200	Rod d 12mm L 200mm
1x939150	Rod d 9mm L 150mm
1x30017	Allen Wrench 5mm
1x91150	Universal "T" Wrench
1x1-1100201	Drill Bit d 4.8x240mm
1x11138	Drill guide d 4.8mm
2x11137	Screw Guide 80mm
1x19950	Drill Guide d 3.2mm L 100mm
1x1-1100301	Drill Bit d 3,2x200mm QC
2x911530	Xcaliber Screws 150/30
2x10137	Cortical Screws 120/20 D 4,5/3,5 Shaft 6mm
1x11146	X-Wire without olive Ø 2mm Length 150mm



GALAXY SHOULDER STERILE KIT (99-93505)

Can accommodate:

Code	Description
4x93310	Small Clamp
3x93620	Wire Locking Clamp
1x936080	Rod d 6mm L 80mm
1x936100	Rod d 6mm L 100mm
1x936120	Rod d 6mm L 120mm
1x936140	Rod d 6mm L 140mm
1x30017	Allen Wrench 5mm
1x19970	Wire Guide
1x91150	Universal "T" Wrench
1x81031	Open end wrench
6x93100	300mm Threaded wire



Out of sterile kit:

- Wire cutter W1003
- Wire bender 19980

TRAY CONFIGURATIONS

Code	Description
93991C	Galaxy Upper + Lower Complete
93992C	Galaxy Instruments Complete
93993C	Galaxy Lower + Instruments Complete
93994C	Galaxy Upper + Instruments Complete
93995C	Galaxy Upper Complete
93996C	Galaxy Lower Complete
93998C	Galaxy Shoulder Complete
93997C	Galaxy Elbow Complete
93999C	Galaxy Wrist Complete

GALAXY SMALL Z-CONFIGURATION STERILE KIT (99-93498)

Can accommodate:

Code	Description
6x93310	Small clamp
1x936120	Rod d 6mm L 120mm
1x936100	Rod d 6mm L 100mm
1x936080	Rod d 6mm L 80mm
2x19995	Sleeve 4,5mm
2x13530	Drill guide d 2.7mm
1x91017	Allen Wrench
4x947320	Self Drilling XCaliber Cylindrical Screw Shaft d 4mm Thread 3mm L 100/20 QC
2x1-1355001	Drill Bit d 2,7mm
1x93160	"T" Wrench AO QC



GALAXY MEDIUM - PAEDIATRIC STERILE KIT - Ø5MM SCREW THREAD (99-93520)

Code	Description
2x93140	Double multipin clamp medium
2x939250	Rod d 9mm L250mm
4x944540	5mm thread self-drilling 150/40 cylindrical screws QC
2x11137	Screw guide 80mm
1x30017	Allen Wrench 5mm
1x93160	QC Wrench

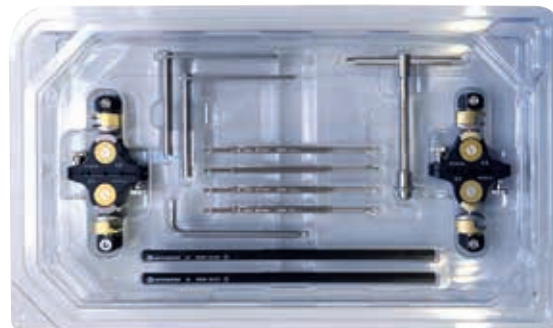

GALAXY MEDIUM - PAEDIATRIC STERILE KIT - Ø4MM SCREW THREAD (99-93521)

Code	Description
2x93140	Double multipin clamp medium
2x939250	Rod d 9mm L250mm
4x944530	5mm thread self-drilling 150/30 cylindrical screws QC
2x11137	Screw guide 80mm
1x30017	Allen Wrench 5mm
1x93160	QC Wrench

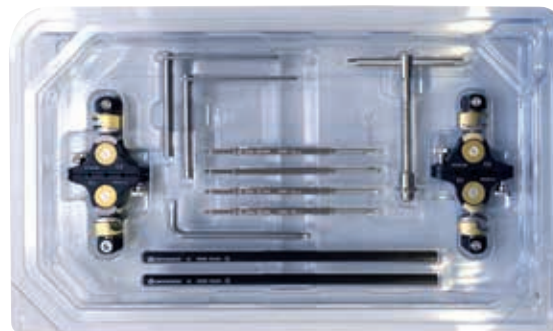

HUMERAL APPLICATION

APPROACH TO THE HUMERUS

When dealing with the humerus, consideration should be given to the radial, axillary, musculocutaneous, ulnar and median nerves and brachial artery and vein. Proximally, screws should be inserted distal to the level of the axillary nerve. They can be placed from a lateral approach or ventro-lateral direction.

The middle segment of the humerus (shaded in red) should be avoided as the radial nerve has a variable course in this area.

Distally, a screw inserted from the lateral side between the triceps and brachioradialis muscles will avoid the radial nerve as long as it is just proximal to the upper border of the olecranon fossa.

A more proximal screw can be inserted just medial to the lateral border of biceps, thereby avoiding the terminal branch of the musculocutaneous nerve. An alternative is a half screw inserted from the dorsal surface.

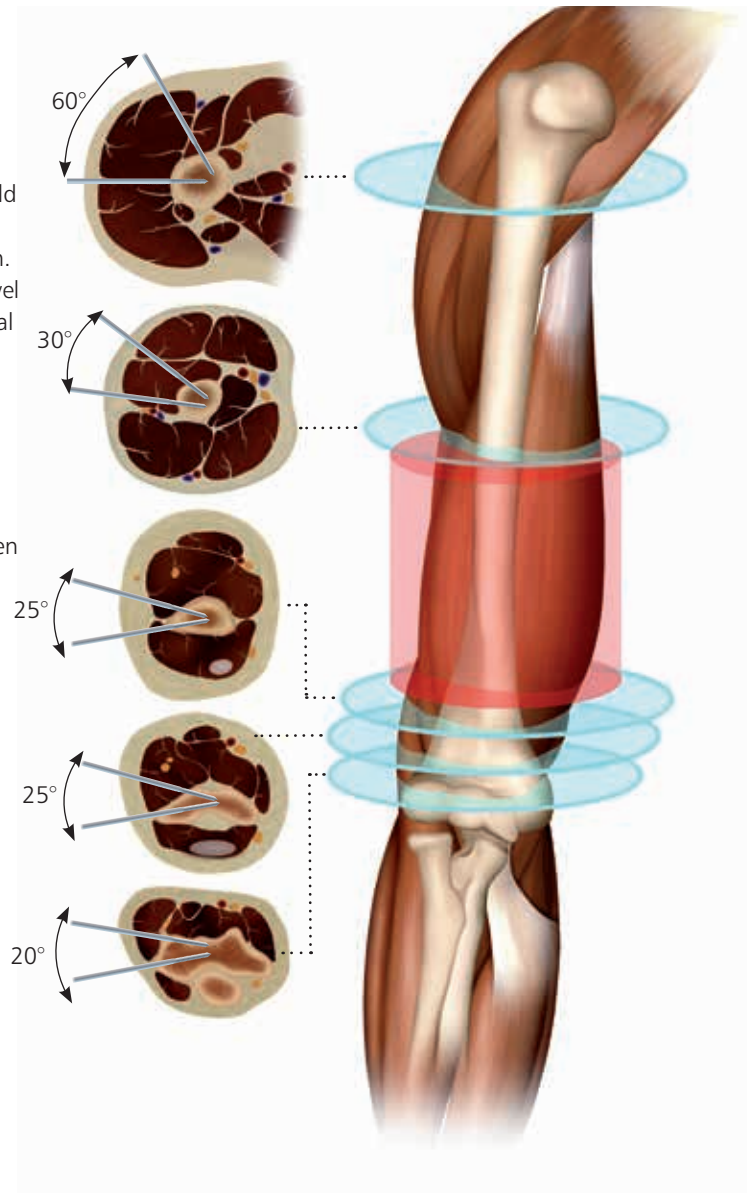

Screw Insertion

Screw positions should be planned with regard to zone of injury; often this may extend beyond the fracture lines visible on X-ray. Further thought into possible future surgeries, including plastic surgical and internal fixation procedures, should be given. X-rays of the fracture in two planes should be available. In general, screws should be placed anterolaterally in the femur; anteriorly (1cm medial to the tibial crest in an anteroposterior direction) in the tibia; laterally in the proximal third of humerus and posterolaterally in the distal third of the humerus. Screws should be positioned for maximum mechanical stability in each bone segment, with bicortical purchase by the screw threads and with each pin as far apart in each segment as the fracture lines and neighbouring joints allow.

Insert two screws into each main fragment free-hand using the following technique:

1) Make a 15mm incision through skin and deep fascia. Use blunt dissection to reach the underlying bone (Fig. 1).

2) Insert a screw guide perpendicular to the longitudinal axis of the bone. Use a trocar to locate the midline by palpation (Fig. 2).

3) Keeping the screw guide in contact with the cortex by gentle pressure, withdraw the trocar, and tap the screw guide lightly to anchor the pronged end against bone (Fig. 3).

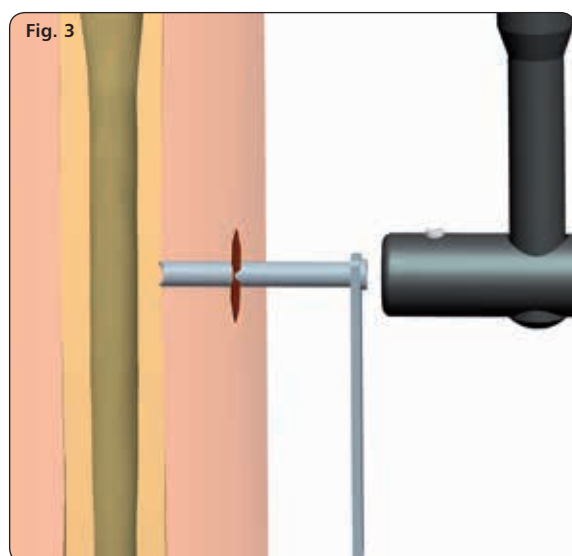
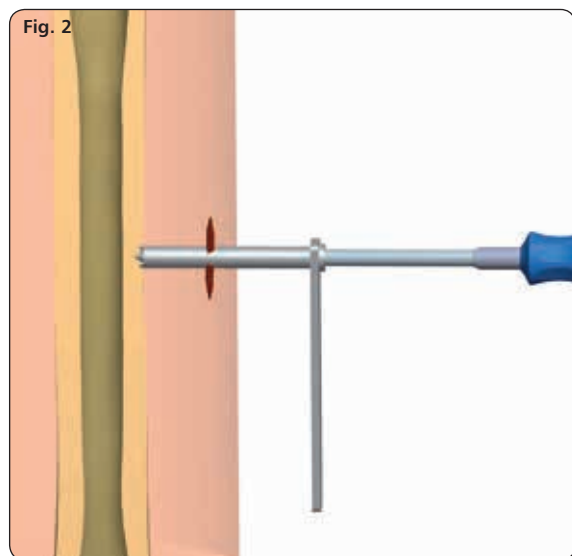
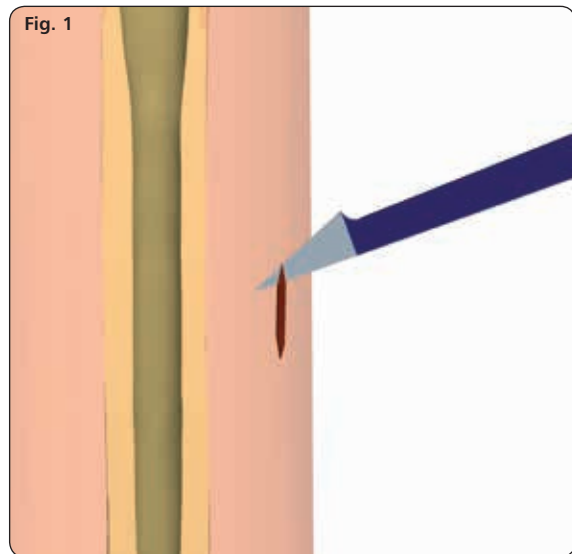

4) Insert a screw through the screw guide into the bone using the Hand Drill (Fig. 4a). While drilling, the hand drill should be held steady so that the drilling direction is maintained throughout the procedure. Once the second cortex has been reached, reduce the drilling speed; four more turns are needed so that the tip just protrudes through the distal cortex. Diaphyseal bone screws should always be inserted across the diameter of the bone to avoid off axis placement. Off axis location of screws may result in screw threads lying entirely within the cortex and not traversing the medullary canal; this may weaken the bone. In all cases the surgeon should be mindful of the amount of torque required to insert the screw. In general, it is safer drill a hole with a 4.8mm drill bit prior to insertion of these screws in diaphyseal bone (Fig. 4b).

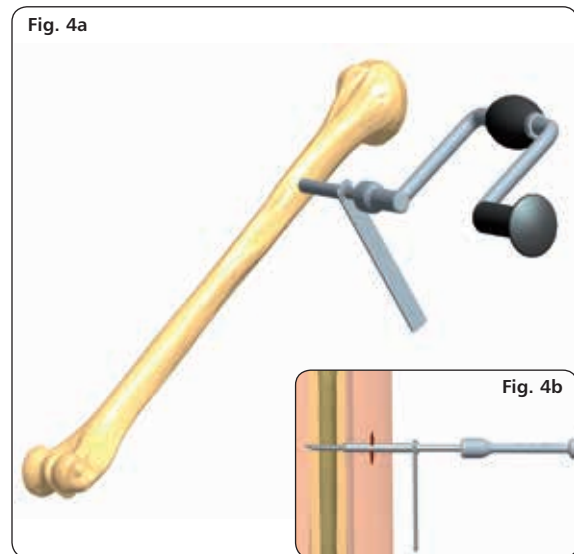

5) If a 6mm thread diameter screw is used, insert the 4.8mm drill guide into the screw guide and introduce 4.8mm drill bit (Fig. 5). Drill at 500-600 rpm through the first cortex, checking that the drill bit is at right angles to the bone. The force applied to the drill should be firm and the drilling time as short as possible to avoid thermal damage. Once the second cortex has been reached, reduce the drilling speed and continue through the bone. Ensure that the drill bit completely penetrates the second cortex.

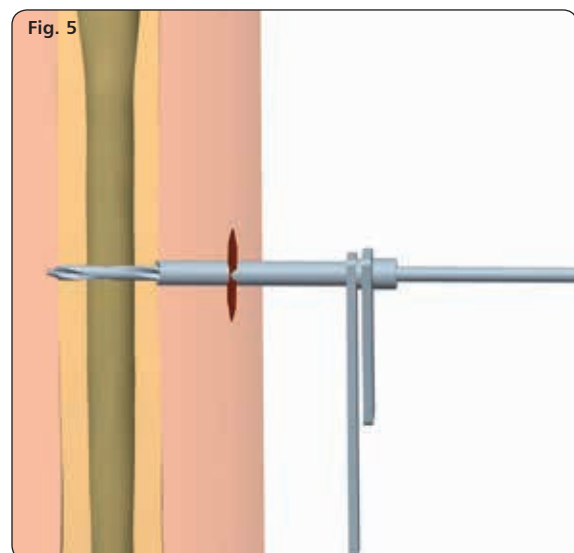

6) Remove the drill bit and drill guide, keeping pressure on the handle of the screw guide. The screw is inserted with the T-Wrench until it reaches the second cortex. A further 4-6 turns are required to ensure that about 2mm of the screw protrudes beyond the second cortex (Fig. 6).

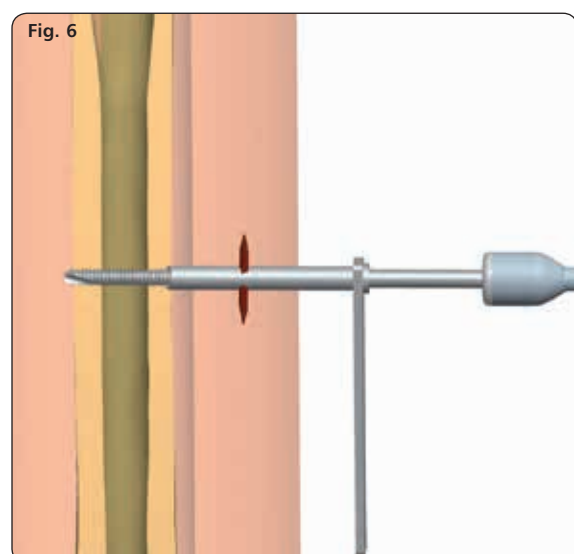

Note: The XCaliber self-drilling screws can be inserted by hand in cancellous bone. Pre-drilling is not often needed in this area. There is no need for the tip of the screw to protrude from the second cortex.

Warning! If thread is tapered, repositioning the screw by turning counter-clockwise more than two turns will loosen the bone-screw interface.

XCaliber bone screw design

The screws have a pointed tip and flute which allow them to be inserted as self-drilling implants in cancellous bone without the need for pre-drilling. Direct insertion with a hand drill is advised in most situations, irrespective of whether uncoated or HA coated screws are used. However, when insertion of these self-drilling screws is performed in diaphyseal bone, pre-drilling is recommended; use a 4.8mm drill bit through a drill guide when the bone is hard. If the bone quality is poor or, as in the metaphyseal region, where the cortex is thin, a 3.2mm drill bit should be used.



XCaliber bone screws should never be inserted with a power tool. This may result in high temperatures and cell necrosis from too high insertion speeds. Screw insertion, whether or not pre-drilling has been performed, should always be with the XCaliber Hand Drill (91120) or Ratchet T Handle + Screw Shaft Connection (93150 + 93155). The screws have a round shank which is gripped securely by the XCaliber T-handle or Hand Drill. It is important that moderate force is applied initially for the screw to engage and gain entry into the first cortex.

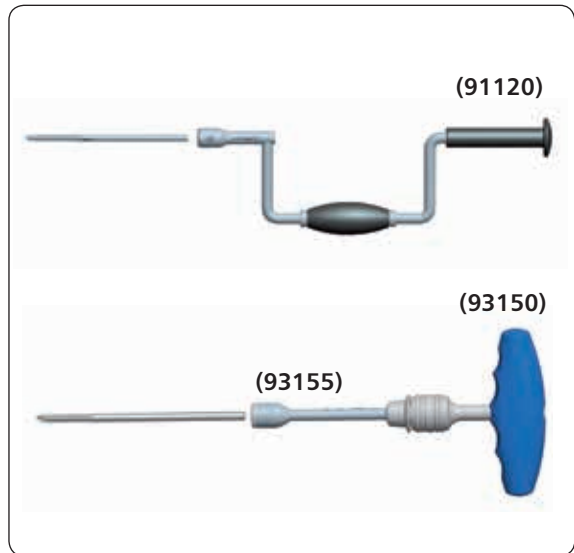

7) Insert the remaining screws using the same technique (Fig. 7).

Fig. 7



Fixator Application

8) The two screws in each bone segment are joined by rods of suitable length; each one mounted with two clamps positioned about 30mm from the skin. They are then locked manually by turning the knurled metal ring clockwise (Fig. 8).

Fig. 8



9) A third rod is then used to join the first two rods together by 2 more clamps, which are not yet tightened. The surgeon now manipulates the fracture, if possible under X-ray control. When the position is satisfactory, the assistant locks all the clamps firmly by tightening the cams with the Universal T-Wrench or the 5mm Allen Wrench (Fig. 9).

Fig. 9



10) The screw shafts are then cut with the bone screw cutter (Fig. 10). Although the screws can be cut before insertion, it is difficult to gauge the length accurately, and it is recommended that they are cut after the fixator has been applied. It is important that all of the screws are inserted first, and the fixator applied with the clamps locked firmly over the screws, about 30mm from the skin. The cutter can then be slid over the screw shafts in turn and the screws cut close to the fixator clamps. This will normally result in about 6mm of screw shank protruding from the clamp. The cutter is designed so that it can be used even when screws are in adjacent seats of the multi-screw clamp. The cut ends of the screws can then be protected with screw caps. When cutting the screws, the arms of the cutter should be extended for greater efficiency and the outer end of the screw held

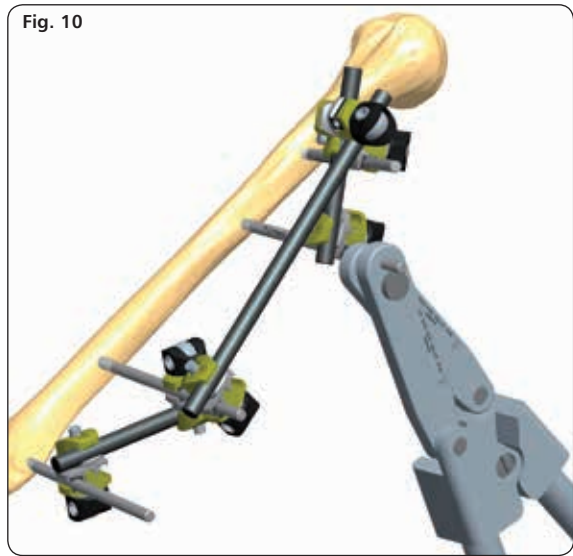

MULTI-SCREW CLAMPS

Insert the first screw into one of the outer holes of the multi-screw clamp guide using the same technique as described above. Insert the second screw in the remaining outer seat and cut both screw shafts with the bone screw cutter. Lastly, insert the central screw if necessary.

Option 1

Use the multi-screw clamp as a template to insert screws perpendicular to the longitudinal axis of the bone (Fig. 11).

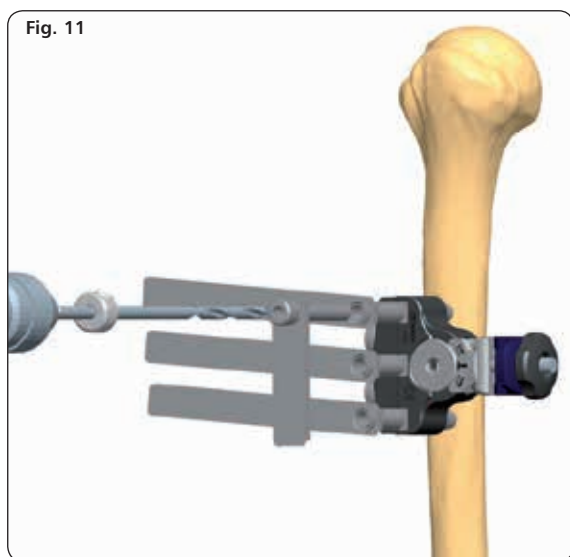

Option 2

Use the Multi-Screw Clamp Guide 19940 as a template to insert screws perpendicular to the longitudinal axis of the bone (Fig. 12).

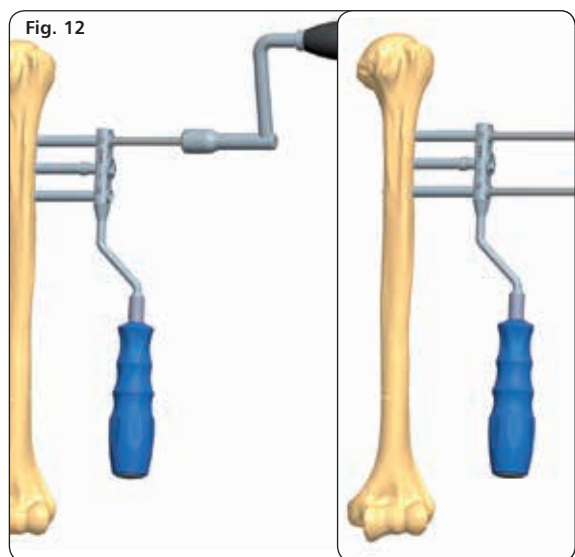

SHOULDER APPLICATION

Galaxy shoulder frame

Simple, standardized and reproducible: frame application guided by anatomical landmarks for most common proximal humeral fracture patterns.

Stable: 7cm threaded paired bicortical wires. Subchondral (in the humeral head) and lateral bone purchase.

Low complication rate: Galaxy Shoulder Fixation significantly reduces pin migration and backing out vs traditional pinning.

Minimally invasive: percutaneous reduction. Fracture fixation with six wires externally stabilized with Galaxy Shoulder components.

End of treatment (Average 6 weeks) corresponds to frame removal without need for a second surgery.

Early passive mobilization and rehabilitation

Versatile: sterile kit, sterile-single packed components, instrument and implant tray.

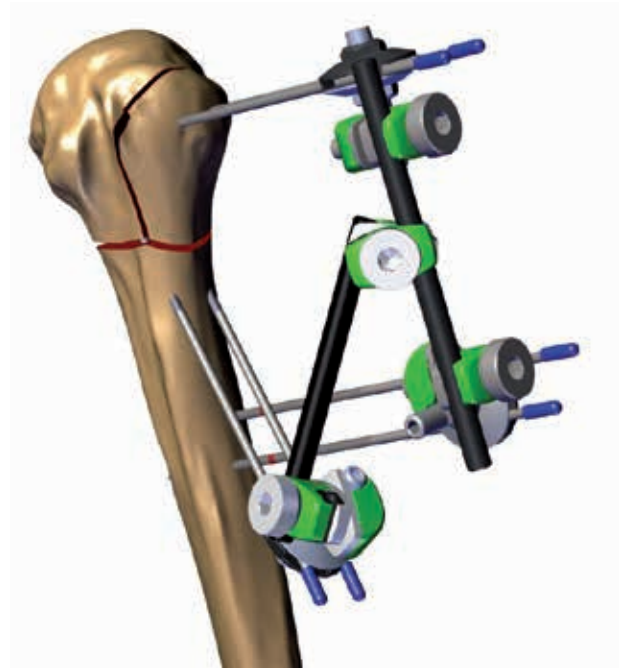

The Galaxy Shoulder operative technique has been updated and replaced by the new one ref "GF-1805-OPT"

ELBOW APPLICATION

Patient Positioning

a) *Positioning of the patient:* the patient is in a supine position. The injured arm is positioned on the table so that radiographs of the humerus can be performed. A tourniquet generally should not be applied. If concomitant injuries make open osteosynthesis necessary (radial head fracture, condyle dislocation, etc.), appropriate bleeding stoppage will be necessary if the fixator is to be applied in the same procedure. As an alternative, osteosynthesis can be first performed separately in a bloodless field. After repeated disinfection and draping, the fixator can then be applied. In this case, it is important to ensure adequate bleeding stoppage to avoid hemorrhage in the operative field after removing the tourniquet. A single-step approach with minimal tissue trauma and use of bleeding stoppage is preferred.

Hint: It can sometimes be useful to raise the shoulder by placing a rolled-up towel below it.

b) *Preparation of the patient:* when performing disinfection, the entire upper limb and shoulder are washed. The arm can be held by the hand during the disinfection process. For this, the patient's hand is wrapped in an adhesive drape. As an alternative, the hand can also be disinfected. The surgeon sits at the patient's head with the assistant on the other side of the patient. The Image Intensifier is moved in from the side. It is important that the surgeon has adequate access to the elbow when the Image Intensifier is in place.

c) *Use of Image Intensifier:* the left figure shows a good position for the monitor. During surgery, the surgeon and assistant should have an unobstructed view of the monitor.

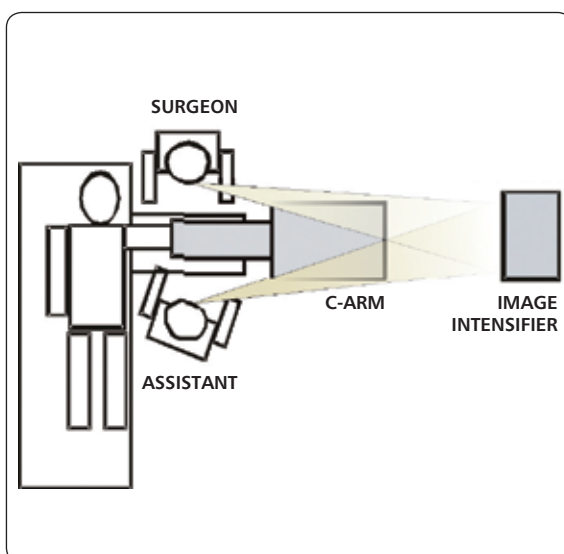

OPERATIVE TECHNIQUE

1) Expose the lateral aspect of the Humerus by blunt dissection in order to avoid damage to the radial nerve, taking into account that the first screw has to be inserted at the proximal level, placed not completely lateral but 10-15 degrees anterior. Use the multi-screw clamp as a template to insert screws perpendicular to the longitudinal axis of the bone. Insert the screw guides and position the trocar (19955), into one of the outer holes of the multi-screw clamp. Use the trocar to locate the midline by palpation (Fig. 1).

NOTE: The middle segment of the Humerus should be avoided as the radial nerve has a variable course in this area.

2) Keeping the screw guide in contact with the cortex by gentle pressure, withdraw the trocar, and tap the screw guide lightly to anchor its distal end. Make sure that there are no soft tissues between the bone and the screw guide. Insert the 4.8mm drill guide (11102) into the screw guide, and drill with a 4.8mm drill bit (11001). Use a sharp drill and make sure that the drill bit is at right angles to the bone, the force is applied to the drill is firm and the drilling time as short as possible to avoid thermal damage (Fig. 2). Once the second cortex has been reached, reduce the drilling speed and continue through the bone. Ensure that the drill bit completely penetrates the second cortex.

3) Remove the drill bit and drill guide, keeping pressure on the handle of the screw guide. Insert a screw through the screw guide into the bone using the T-wrench (Fig. 3) or hand drill. While drilling, the hand drill should be held steadily so that the drilling direction is maintained throughout the procedure. The screw should completely engage the second cortex for bicortical purchase. Use the same technique for the second screw.

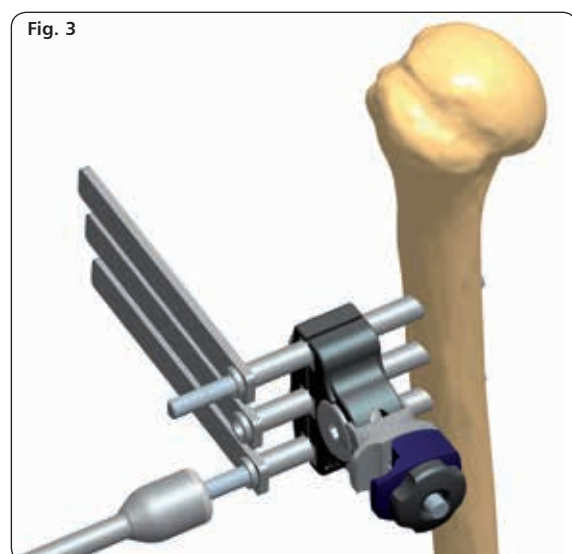
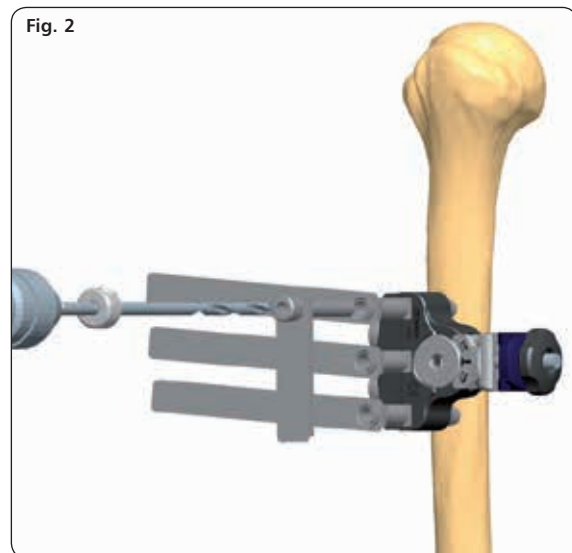
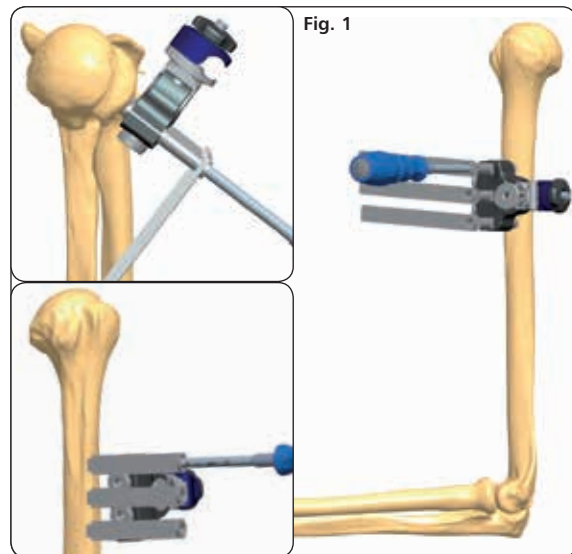

If XCaliber screws are used, cut both screw shafts with the bone screw cutter. Lastly, insert the central screw if necessary (Fig. 4).

NOTE: In all cases the surgeon should be mindful of the amount of torque required to insert the screw. If it seems tighter than usual, it is safer to remove the screw and clean it, and drill the hole again with a 4.8mm drill bit, even if it has already been used.

Warning! As the thread is tapered, repositioning the screw by turning counterclockwise more than two turns will loosen the bone-screw interface.

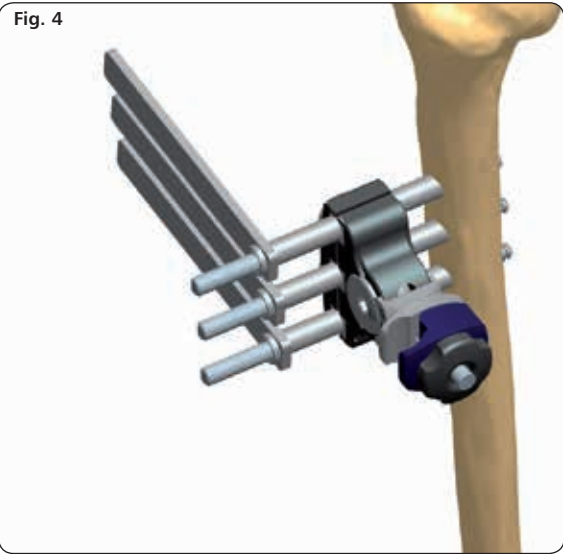

5) Remove the 3 screw guides and lock the screws in the clamp (Fig. 5).

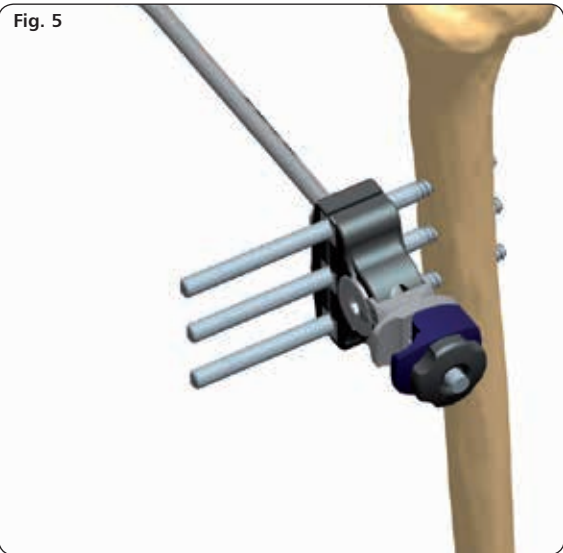

6) Choose a 12mm rod of appropriate length and connect it to the Multi-screw Clamp and to the Elbow Hinge (93410). Lock the rod to the hinge (Fig. 6).

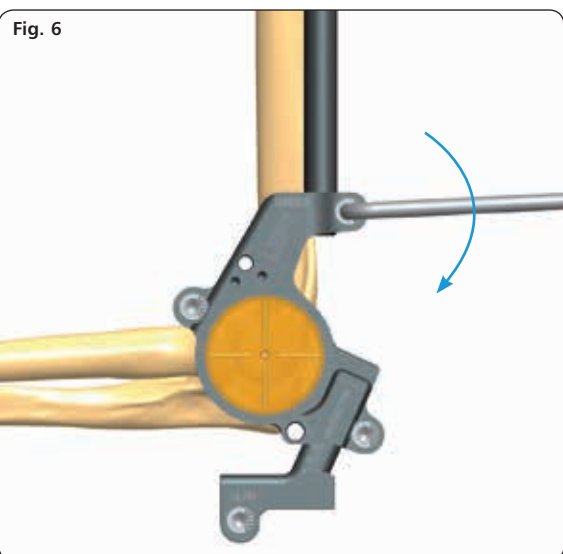

The Elbow Hinge needs to be aligned with the centre of rotation of the joint and in order to achieve this:

- With the rod parallel to the longitudinal axis of the humerus, ensure that the Hinge is vertically aligned with the center of rotation of the joint and lock the rod to the Multi-screw Clamp by turning the knurled metal ring by hand (Fig. 7).

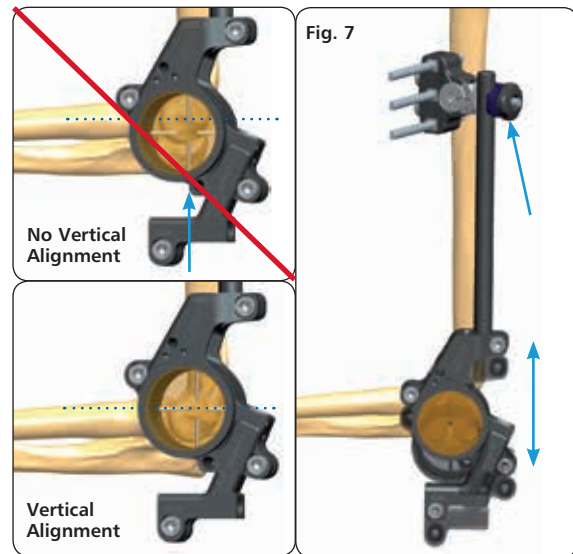

- Move the rod antero-posteriorly to achieve horizontal alignment (Fig. 8).

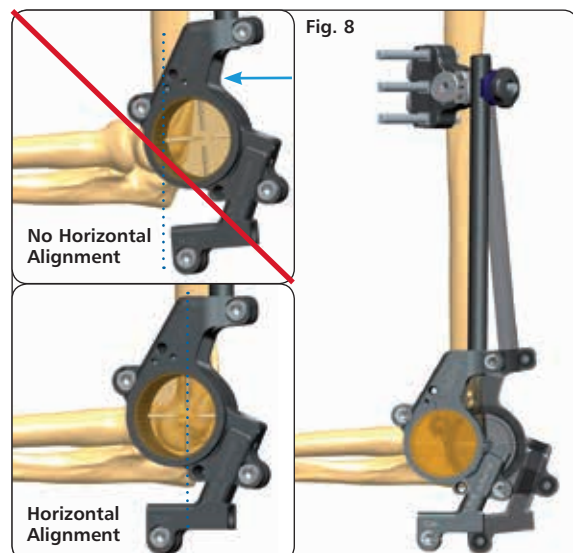

- Rotate the Elbow Hinge until perfectly aligned with the center of the elbow joint in the lateral view (Fig. 9).

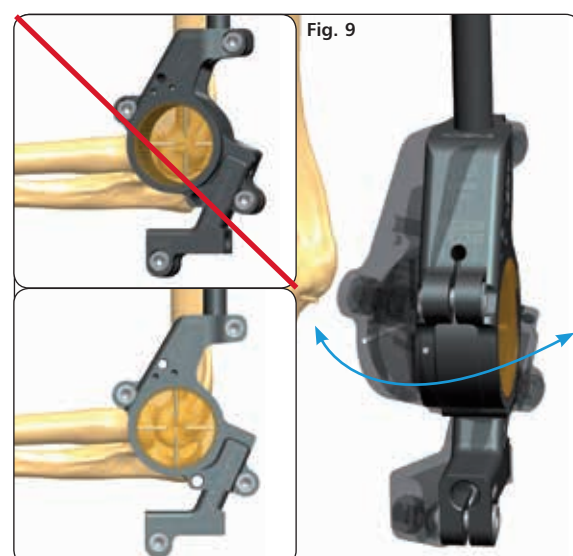

7) Lock the Multi-screw Clamp Central Nut and check Elbow Hinge alignment under image intensification. (Fig. 10). The radiolucent central unit of the hinge has an in-built targeting cross which can be used to achieve a correct alignment, however it is advisable to use an additional 2mm k-wire (length approx. 10cm). Insert the k-wire through the hole in the centre of the hinge unit and manipulate the central hinge unit until the k-wire projects as a dot in the center of the condyles.

If necessary, a third screw can be inserted distally in the humerus to increase stability (caution to the radial nerve). In this case the screw should be inserted from a dorsal-lateral direction into the distal humerus leaving the radial nerve ventrally. Ensure the safety position of the screw by a mini-open approach.

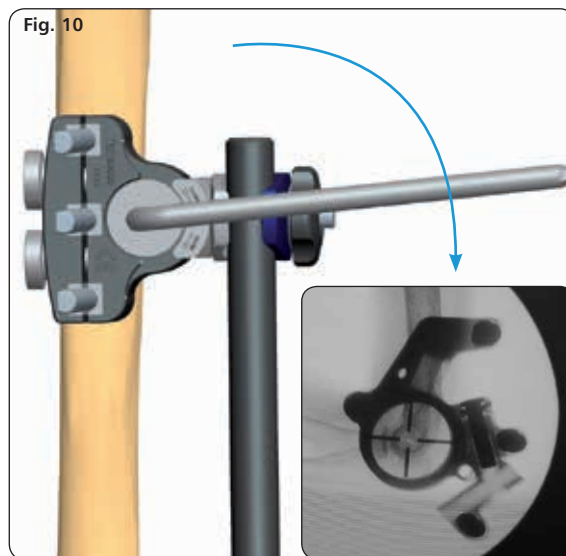

8) Choose a 9mm rod of appropriate length, lock it to the Elbow Hinge and attach a 9mm Clamp to it. With the forearm in neutral position or pronation, align the ulnar rod with the ulna shaft. The ulnar screws may reach the shaft from the lateral side or from a slightly latero-dorsal side. A minimum of 2 screws are necessary. The screws should be well spaced for mechanical stability and they are positioned using the Galaxy Medium Clamps. For predrilling, insert the 3.2mm drill guide (11116) directly into the screw seat of the clamp and drill with the 3.2mm drill bit (11003) (Fig. 11).

9) Insert a 120/20 4.5-3.5mm cortical screw (10137) (Fig. 11a). The distal screw should be inserted first taking care that the ulnar rod is parallel to the posterior border of the ulna. After insertion of the distal screw, the clamp has to be locked tightly before the second screw hole is prepared.

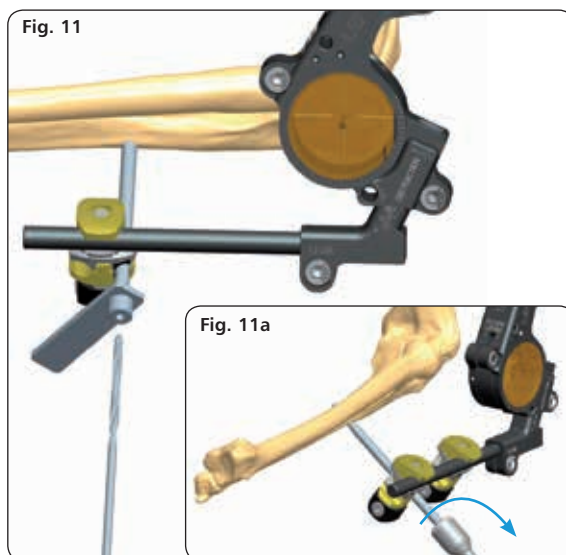

10) While predrilling the second screw hole – again using the drill guide – the clamp must be fully closed. Depending on the soft tissue conditions, the elbow hinge unit can be locked for a short post-operative time (Fig. 12) or can be left open for immediate mobilisation.

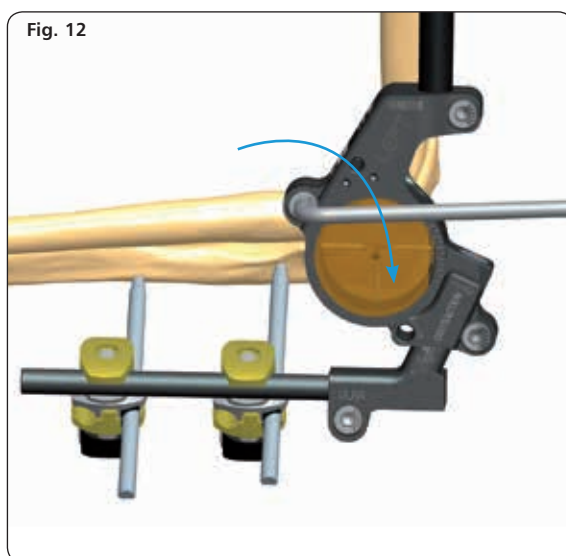

11) The in-built distraction unit is not necessarily used in an acute elbow trauma. Sometimes it may help to protect the joint surfaces but distraction should be limited to 3-4mm. (Fig. 13).

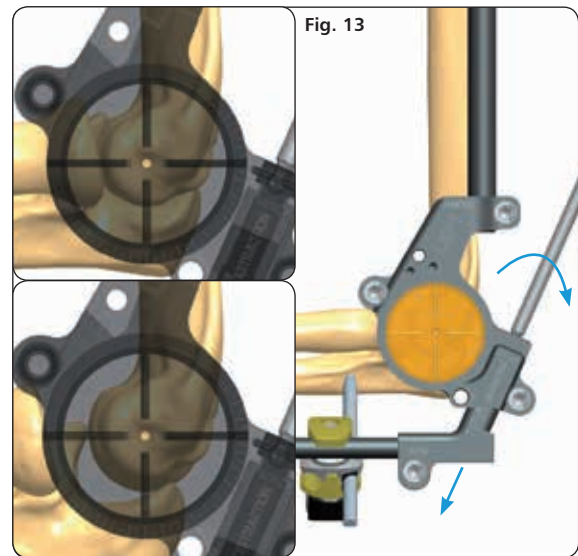

12) *Option:*
Alternatively to the non-invasive targeting technique described above, it sometimes might be helpful to insert a 2mm K-wire into the center of the condyles. The K-wire is percutaneously inserted from the lateral side and its tip centered into the radiologically visible centre of the condyles (Fig. 14).



13) With the K-wire at the entry point of the bone, the K-wire is then drilled approx. 4cm into the bone, along the joint axis both in the lateral and AP view (Fig. 15).

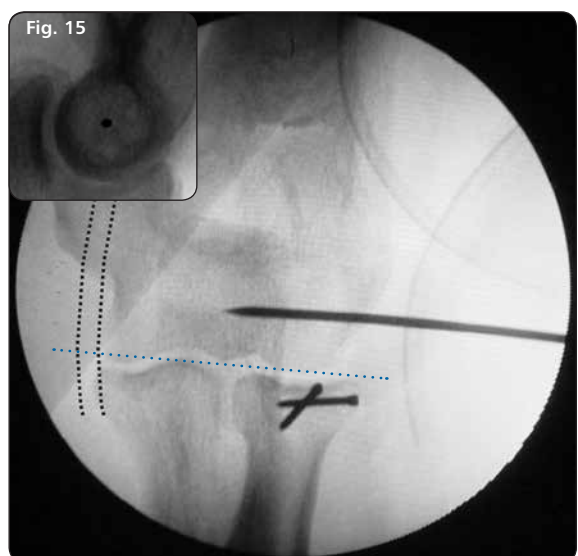

14) If the wire has not been inserted exactly along the joint axis, it is seen as a small line instead of a dot in the lateral view. In this case, under fluoroscopy bend the wire exiting from the skin until it is seen as a single dot (Fig. 16).

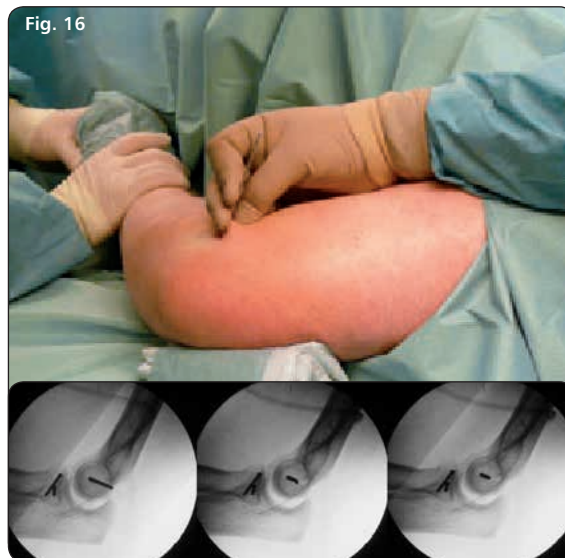

15) The elbow assembly is then slid over the K-wire and previously inserted the humeral screws - see above described technique (Fig. 17).

The Multi-screw Clamp is then closed fully and the application of the fixator is continued with the insertion of the ulnar screws as described above.

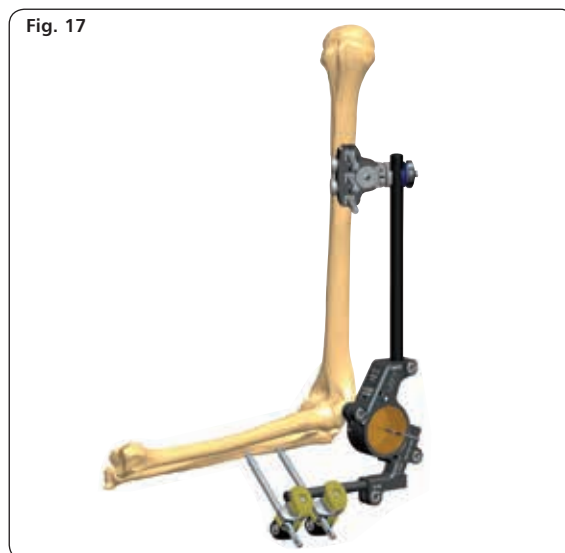

ELBOW MOVEMENT

Free Movement

With locking screw (A) loosened, the Elbow Hinge will allow free flexion-extension (Fig. 1).

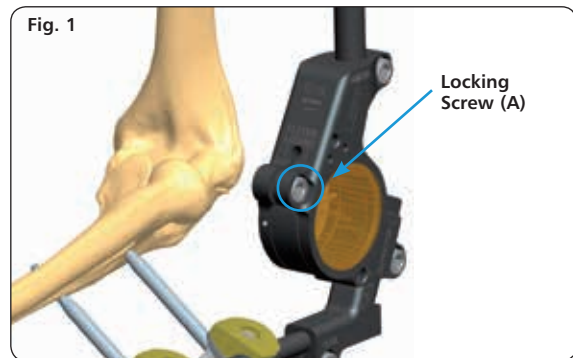

Passive Movement

1) The elbow motion unit allows either a free movement of the elbow joint or a controlled movement towards flexion and extension by turning the worm-screw clockwise or anti-clockwise with the 5mm Allen Wrench (Fig. 2).

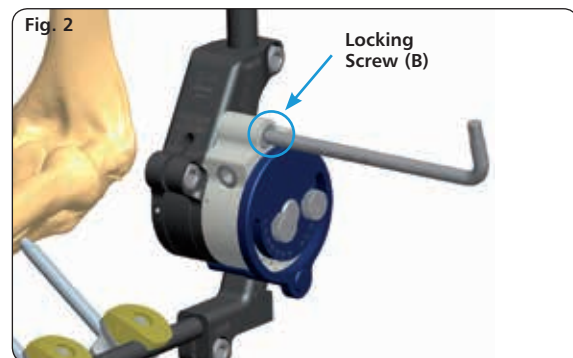

2) Passive flexion and extension is achieved by turning the worm-screw clockwise or anti-clockwise with the 5mm Allen Wrench (Fig. 3).

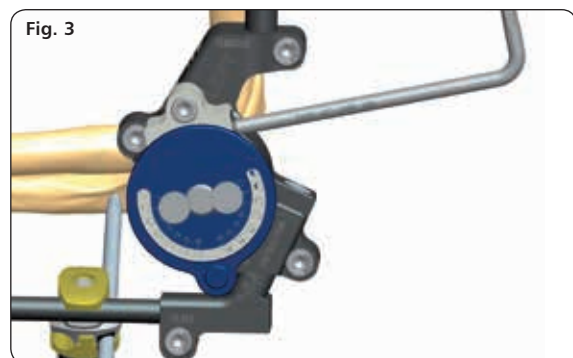

Limited Movement

3) If the screws are removed from the central part of the elbow motion unit, they can be used to limit the amount of flexion and extension (Fig. 4).

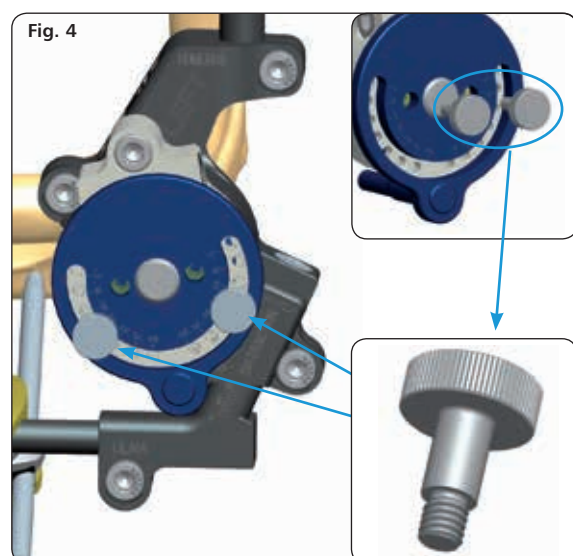

ELBOW DISTRACTOR UNIT POST-TRAUMATIC STIFFNESS

The Elbow Distractor is intended to be used to distract the joint intra-operatively in case of elbow stiffness.



1) It is mandatory to expose or free the ulnar nerve prior to distraction and arthrolysis (Fig. 1).



2) Cleaning of the joint might be necessary prior to the application of the Elbow Distractor. Expose the lateral aspect of the Humerus by blunt dissection in order to avoid damage to the radial nerve, taking into account that the proximal screws are inserted first, on the antero-lateral side, at an angle of 10-15° to the frontal plane (Fig. 2).

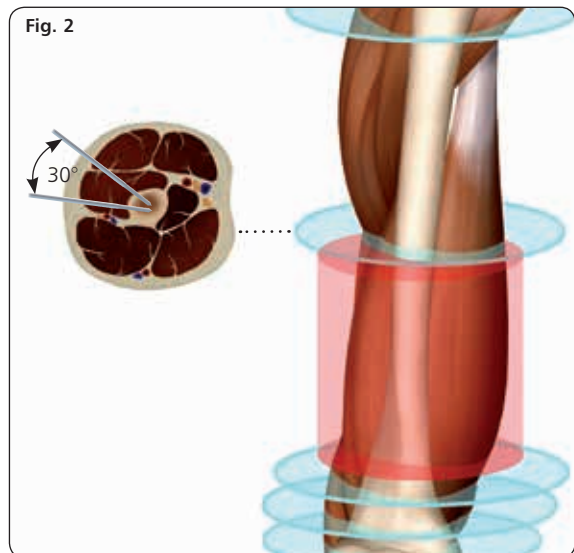

NOTE: The middle segment of the Humerus (shaded in red) should be avoided as the radial nerve has a variable course in this area.

3) Use the Humeral Distractor Clamp as a template for screw insertion. Insert the Screw Guides into the clamp, perpendicular to the longitudinal axis of the bone, and position the Trocar (19950) into one of the outer holes to locate the midline by palpation (Fig. 3).

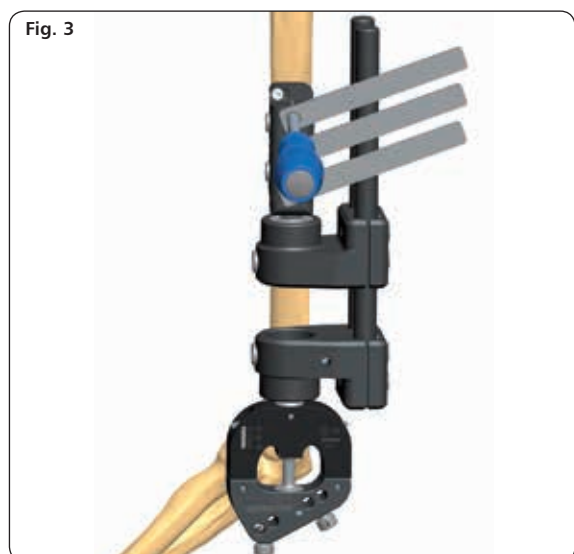

4) Keeping the Screw Guide (11137) in contact with the cortex by gentle pressure, withdraw the Trocar (19955), and tap the Screw Guide lightly to anchor its distal end. Insert the 4.8mm Drill Guide (11138) into the Screw Guide, and introduce a 4.8mm Drill Bit (11001) (Fig. 4).

Drill at 500-600 rpm through the first cortex, checking that the Drill Bit is at right angles to the bone. The force applied to the drill should be firm. Use a sharp drill and make sure that the drilling time is as short as possible to avoid thermal damage.

NOTE: The positions of the screw seats in the Humeral Distractor Clamp refer to the screw seats of the Galaxy Multi-screw Clamp or the 1, 3, 5 screw seats of the LRS ADV Straight Clamps.

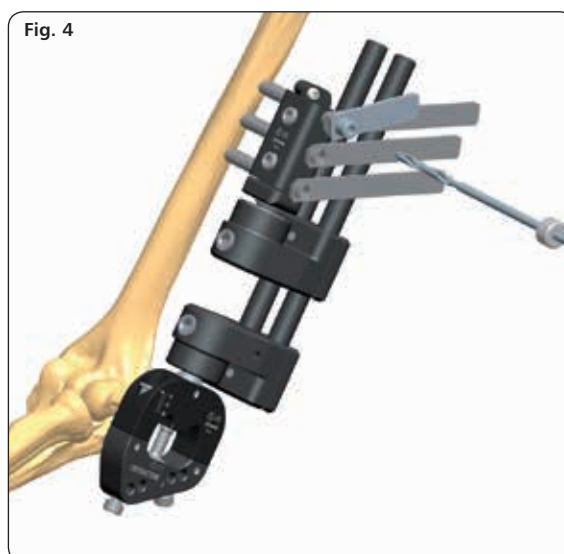

5) Once the second cortex has been reached, reduce the drilling speed and continue through the bone. Ensure that the drill bit completely penetrates the second cortex. Remove the Drill Bit and Drill Guide, keeping pressure on the handle of the Screw Guide. Insert a 110/30 cortical screw (10110) or if necessary a longer screw through the Screw Guide into the bone using the Universal T Wrench (93150+93155) (Fig. 5).

While inserting the screw, the T Wrench should be held steady so that the direction of insertion is maintained throughout the procedure. Make sure that the tip of the screw protrudes through the distal cortex (Image Intensifier).

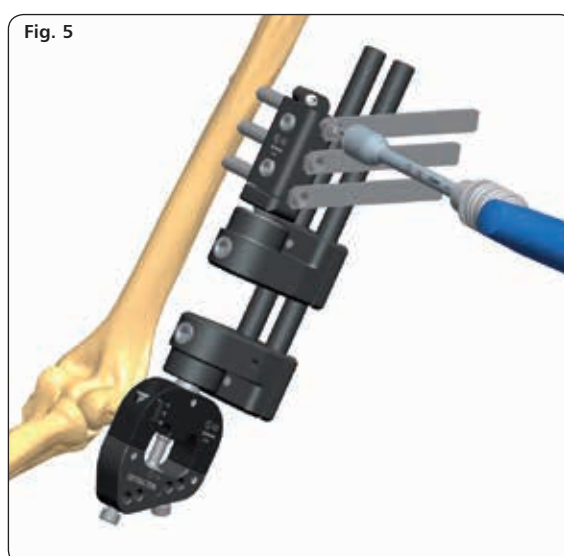

6) Insert the second screw in the outermost hole using the same technique. If XCaliber screws are used, cut both screw shafts with the Bone Screw Cutter (91101). Lastly, insert the middle screw if necessary. Remove the Screw Guides and tighten the clamp (Fig. 6).

NOTE: In all cases, the surgeon should be mindful of the amount of torque required to insert the screw. If it seems tighter than usual, it is safer to remove the screw and clean it, and drill the hole again with a 4.8mm Drill Bit, even if it has already been used.

Warning! As the thread is tapered, repositioning the screw by turning counterclockwise more than two turns will loosen the bone-screw interface.

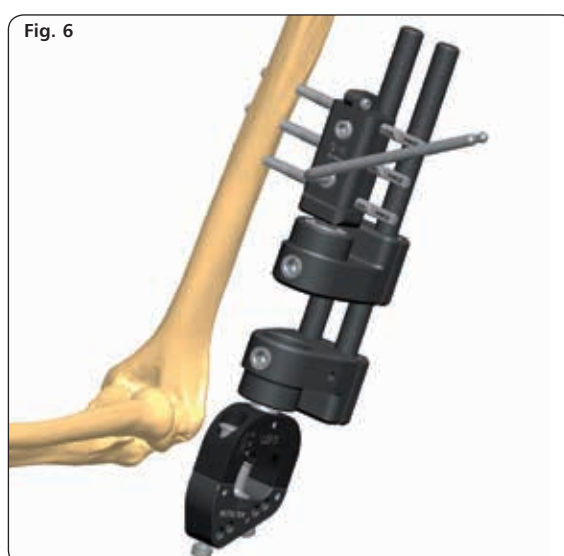

7) With the Ulnar Micrometric Distraction Mechanism in Close position, adjust the distance of the Humeral Distractor Clamp, making sure that the Ulnar Distractor Clamp is aligned with the Ulna (Fig. 7).

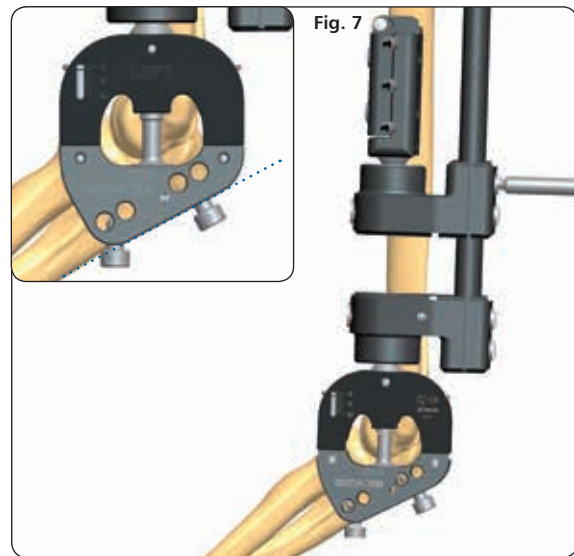

8) To ensure that distraction between the Humerus and Ulna is carried out in a concentric way without any impingement, the axis of the Micrometric Distraction Mechanism should be perpendicular to the virtual line between the coronoid and olecranon (Fig. 8).

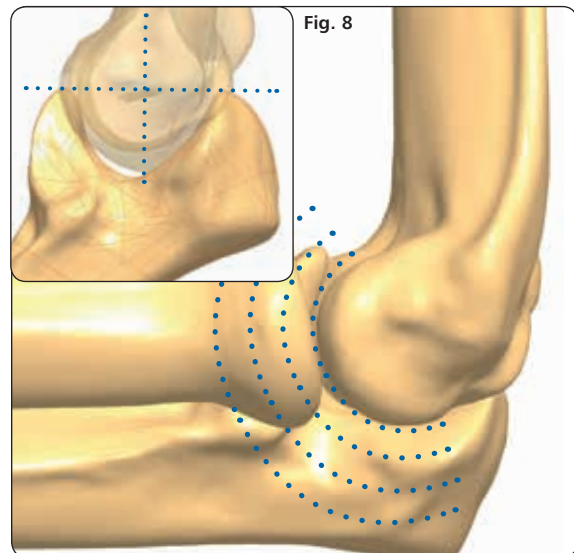

9) Tighten the ball-joints with the Allen Wrench (10017) (Fig. 9).

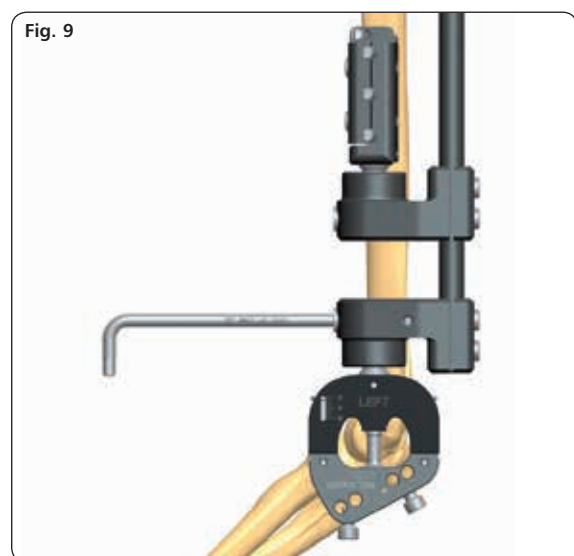

10) Insert now the temporary ulnar screws for distraction. Position the Trocar (19955) in one of the available holes of the Ulnar Distractor Clamp and locate the bone. The distal screw is usually inserted first, preferably opposite to the coronoid process. Remove the Trocar, insert a 3.2mm Drill Guide (19950) and drill with a 3.2mm Drill Bit (11003) (Fig. 10a). Insert a 4.5-3.5mm bone screw (10135 or 10137) (Fig. 10b).

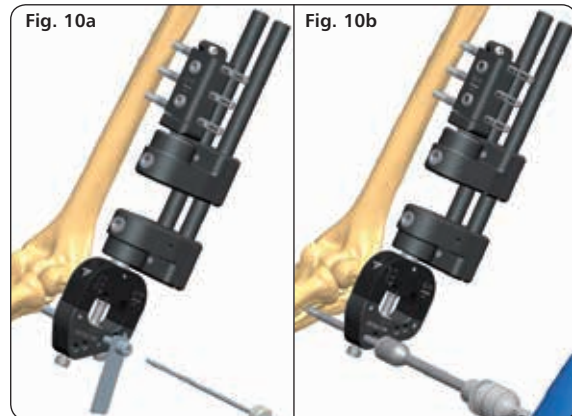

11) If necessary, adjust the position of the Ulnar Distractor Clamp so that its distal border is aligned with the ulna (Fig. 11b). Insert a second ulnar screw in one of the remaining holes of the Ulnar Distractor Clamp using the same procedure. This second screw should enter the olecranon.

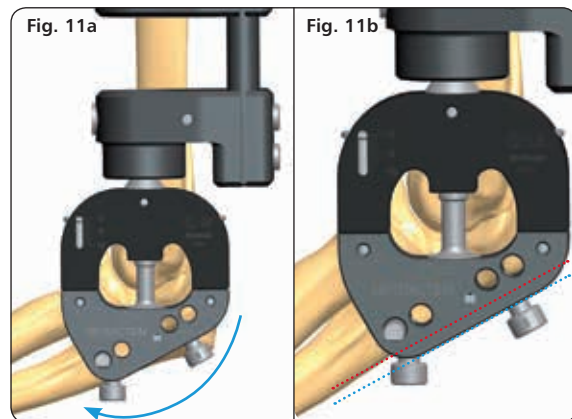

12) Tighten the screw into the clamp with the 5mm Allen Wrench (30017) and tighten the cams with the 6mm Torque Wrench (10025) (Fig. 12).

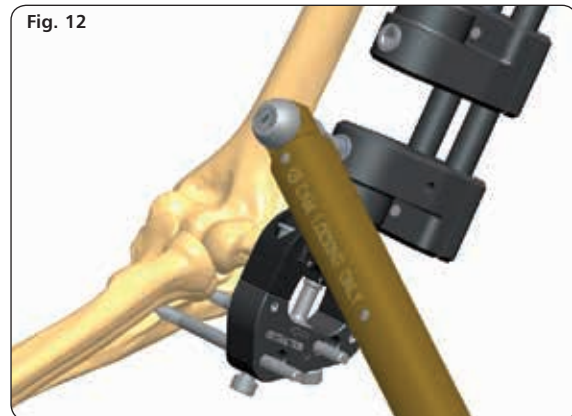

13) Apply joint distraction by turning the Micrometric Distraction Mechanism with 5mm Torque Wrench (93440) which indicates the distraction force (9 Nm correspond approximately to 100 Kg of distraction force) (Fig. 13a e 13b). Joint distraction is checked under image intensification and the appropriate amount of distraction should be decided by the surgeon, in accordance with clinical and radiological findings.

During the distraction process, the ulnar nerve should be monitored closely to make sure that there is no tension on the nerve. If necessary the ulnar nerve has to be trans-posed to the ventral side. The distraction process should be repeated 2-3 times and might take 5-10 minutes to relax the capsule and the collagenic fibres in the ligaments. At the end, release the distraction, remove the temporary ulnar screws and the Elbow Distractor.

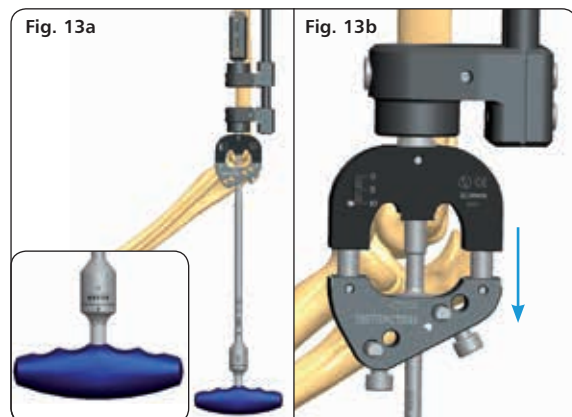

14) Leave the humeral screws in place for the application of the Elbow Hinge Fixator. After having centered the hinge fixator as described from page 26 onwards and inserted the ulnar screws, use the in-built distractor unit (central unit) and re-distract the elbow minimum twice the normal joint space. Do not exceed 10mm. Once the articular surfaces have been separated in this way, the elbow joint can be forced gently into flexion and extension. The resistance must be overcome by controlled continued manipulation. The ulnar nerve must be monitored. If a severe extension deficit is treated by forcing the elbow into extension, care has to be taken to the radial nerve as this manoeuvre might damage it (Fig. 14).

Fig. 14

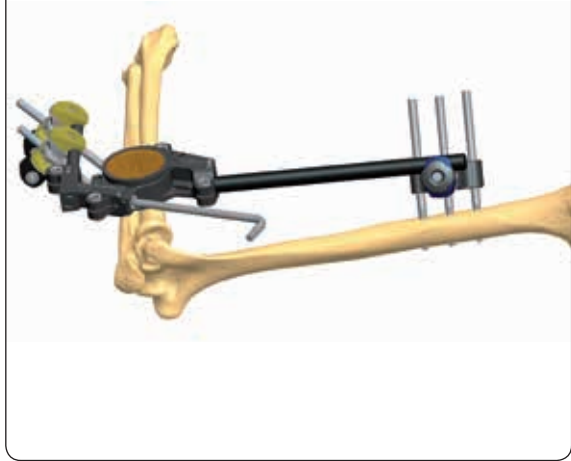

15) Lock the Elbow Hinge in the maximum flexion and leave the elbow in this position for 1-3 days. After this period allow elbow mobilisation (Fig. 15), advising the patient to use the elbow motion unit.

ATTENTION: Pain releasing drugs can be given as soon as the neurological situation (motor and sensory function) in the operated arm is fully intact and there is no severe swelling of the forearm which could be a cause and early sign of compartment syndrome. The external fixator should be kept in place for 6-8 weeks. During this time Indometacin or equivalent drugs may be administered to release pain and inflammation at the same time. A stomach protection could be advisable.

Fig. 15

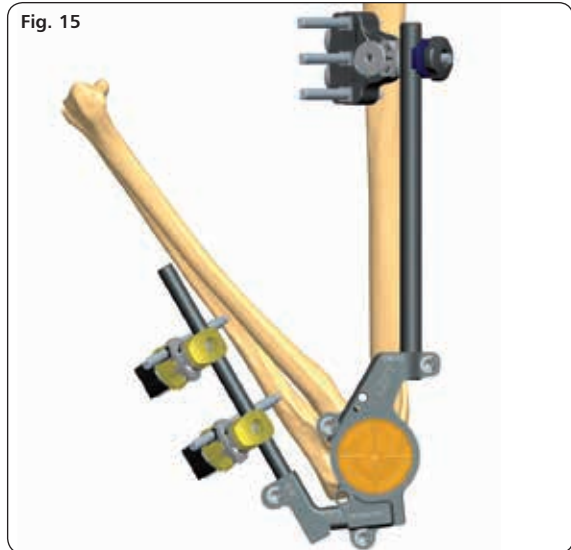

WRIST APPLICATIONS

APPROACH TO THE WRIST

Proximal screws are placed within the middle third of the radius. At this level the radius is covered by the tendons of extensor carpi radialis longus (ECRL) and extensor carpi radialis brevis (ECRB) as well as the extensor digitorum communis (EDC). Screws can be inserted in the standard midlateral position by retracting the brachioradialis (BR) tendon and the superficial radial nerve (SRN), in the dorsoradial position between the ECRL and ECRB or dorsally between the ECRB and EDC. Screw placement is done through a limited open approach to insure identification and protection of the radial sensory and lateral antebrachial-cutaneous nerves.

In non-bridging wrist applications, the distal screws must be applied in the safety zones between the extensor compartments dorsally and dorsoradially.

In wrist bridging applications, the distal screws are applied into the second metacarpal bone, paying attention to the extensor tendon and the radiodorsal neuro-vascular bundle on the extensor and radiodorsal side. If the screws are placed too laterally, they will impede the function of the thumb. For this reason, an angle of 30-45° dorsally from the frontal plane is preferable.

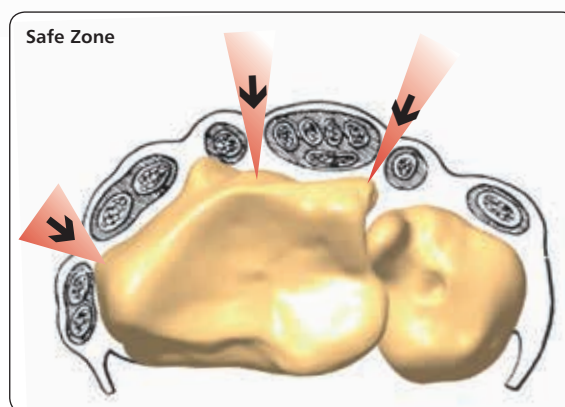
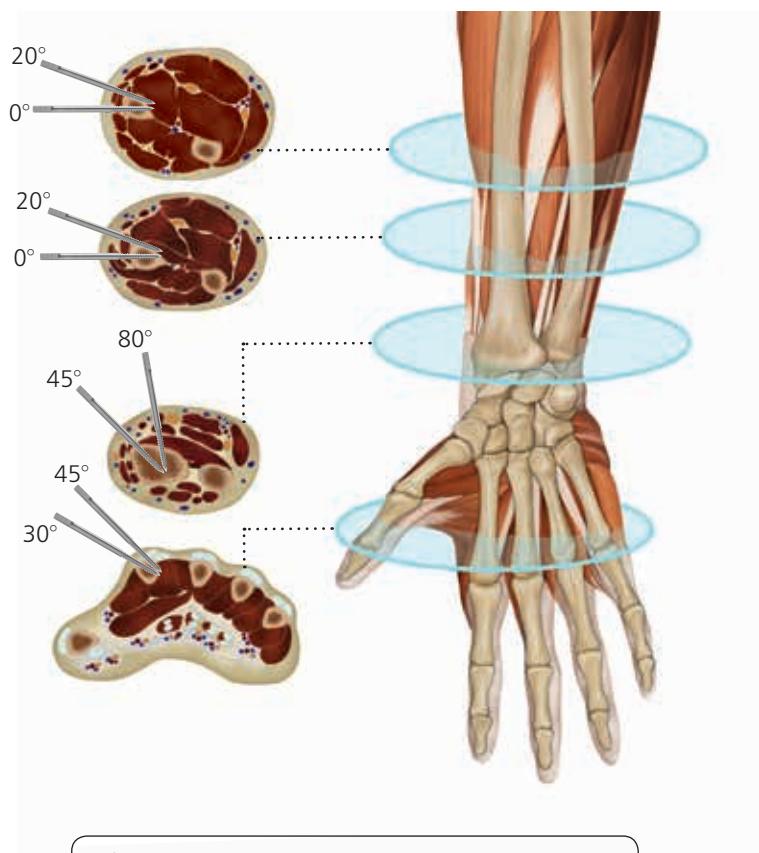

INTRA-ARTICULAR APPLICATION**Surgical Area Preparation**

- Regional or general anaesthesia may be used
- Tourniquet should be available if desired
- Use a hand table
- Make sure that X-ray equipment is available
- Reduce approximately the fracture before the fixator is applied
- Place the wrist in moderate (manual) traction, flexion and radial abduction (i.e. ulnar deviation) with a folded towel on the ulnar side to support it (Fig. 1)

Fig. 1

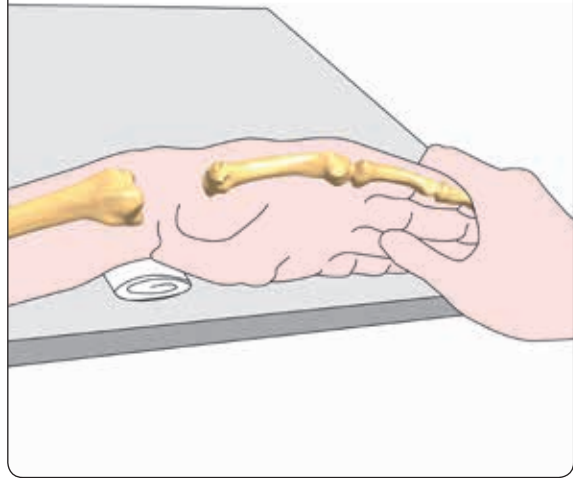
**Distal Screws Insertion**

- Insert first the proximal metacarpal screw close to the base of the bone on the flare of the tubercle
- Make a longitudinal incision to the skin for each metacarpal screw
- Dissect the soft tissues down to the bone taking care to retract the interosseus muscle anteriorly and the extensor muscle dorsally
- The screw guide is positioned on the bone with the trocar (19965) (Fig. 2)

Fig. 2

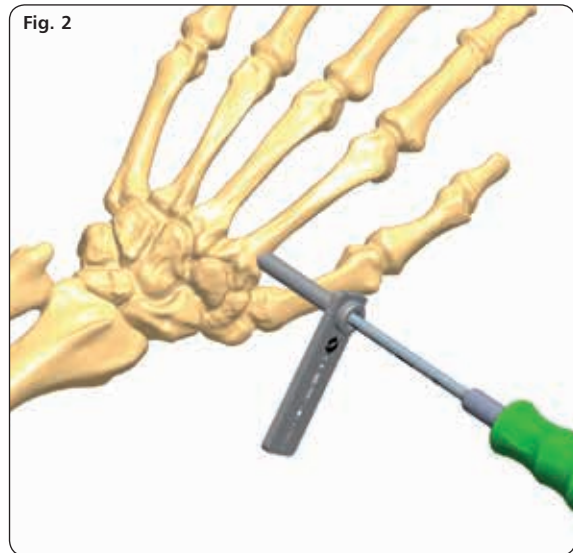

- Insert the screw following one of the screw insertion techniques described below:

***Pre-drilled Bone Screws (4mm shaft) Insertion**

- Remove the trocar, replace it with the drill guide and drill the bone over the drill guide with a 2.7mm drill bit (Fig. 3)

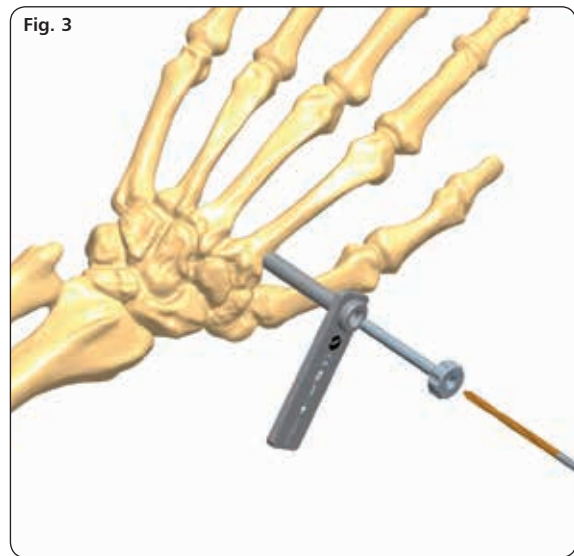

- Insert a bone screw with the T-Wrench 4mm Shaft (93175) or the T-Wrench (M210) over the screw guide (Fig. 4)

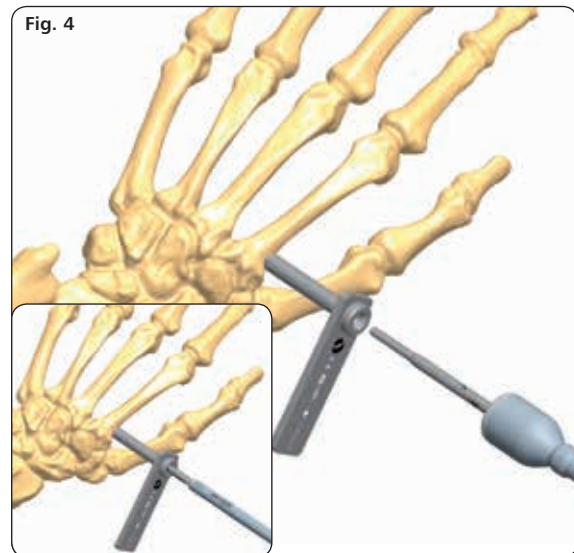

Cylindrical Bone Screws (4mm shaft) and *Self-drilling Bone Screws (3 or 4mm shaft) Insertion

- Remove the trocar and insert the screws directly through the screw guide without pre-drilling. In case of the 4mm cylindrical screws, they are inserted using either the Screw T-Wrench QC (93160) or power drill with moderate speed. In case of the 3mm or 4mm shaft conical screws, they are inserted using either the T-Wrench (M210) or power drill with moderate speed (Fig. 5)

NOTES:

- Take care to avoid damage to the carpo-metacarpal joint
- There is no need for the tip of the screw to protrude from the second cortex
- Great care must be taken to ensure that the screws are inserted in the central bone axis

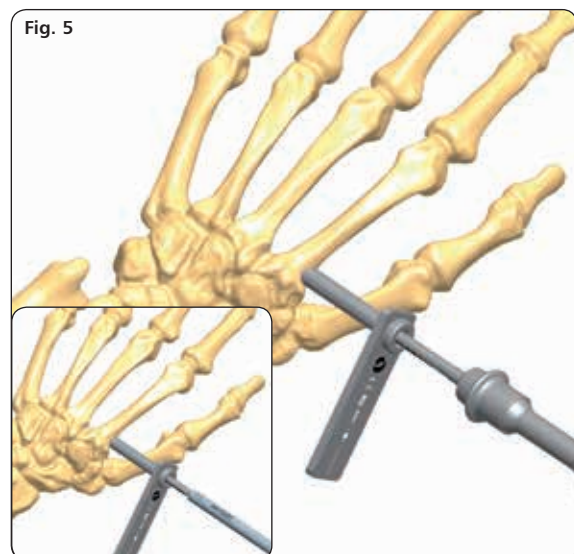

* **WARNING:** Due to their tapered design, screws become loose if they are backed out

Small Multi-screw Clamp-Short positioning

- For an easier application of the second screw, it is advisable to temporarily fix a rod to the clamp and use it as handle
- Insert the two screw guides into the clamp (Fig. 6)
- Insert the Small Multi-screw Clamp-Short (93330) over the first metacarpal screw

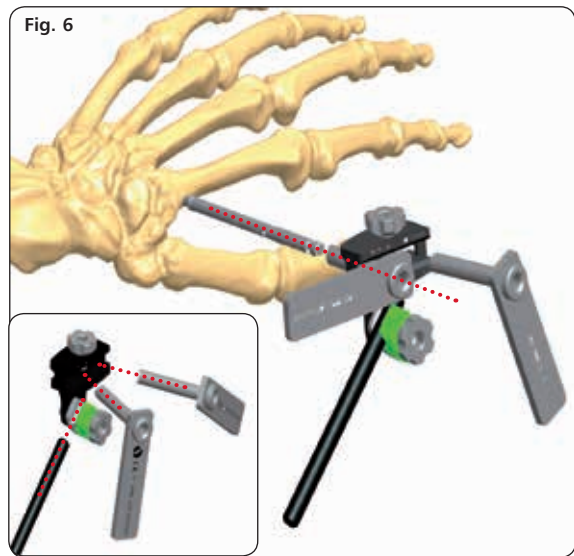

- Use the Small Multi-screw Clamp-Short (93330) as guide to insert the second distal screw, leveraging on the rod-handle to find the most appropriate position on the bone using the trocar (Fig. 7-8)

NOTE: it is important to identify the central axis of the second metacarpal bone for the correct insertion of the distal screw

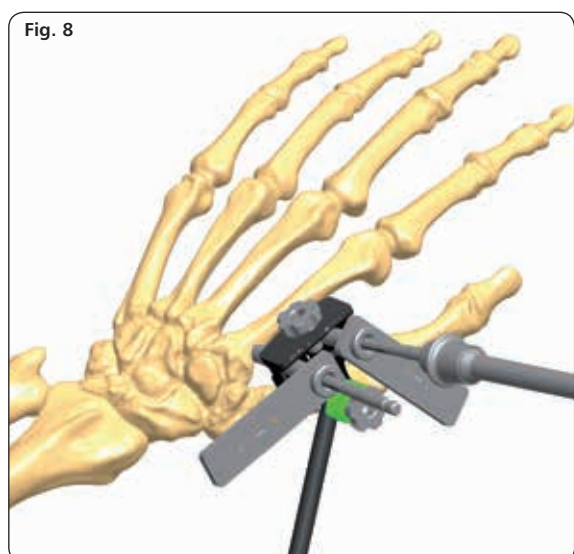
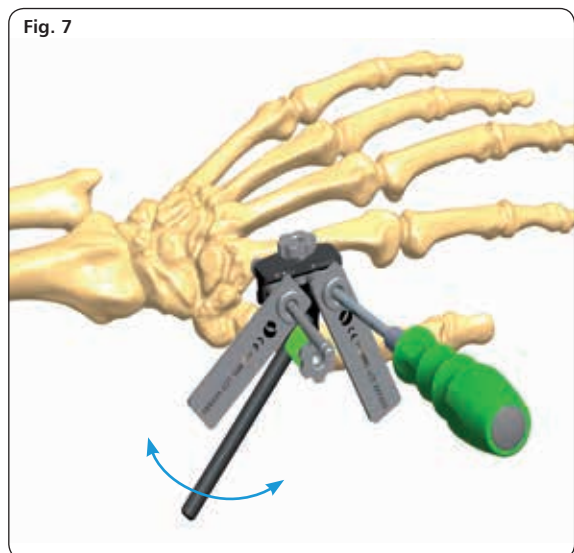

- Remove the temporary rod-handle and the screw guides
- Close the clamp cover by hand to secure the screws (Fig. 9)

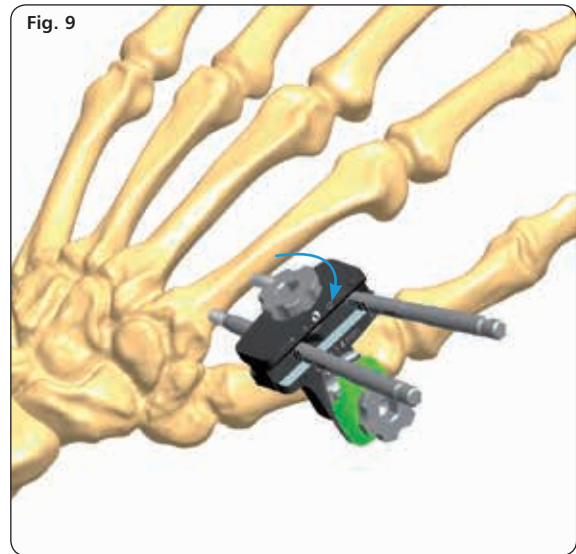

- Set up the wrist module in neutral position with the two rods longitudinally aligned and tighten the Arch Nut with the Allen Wrench (Fig. 10)

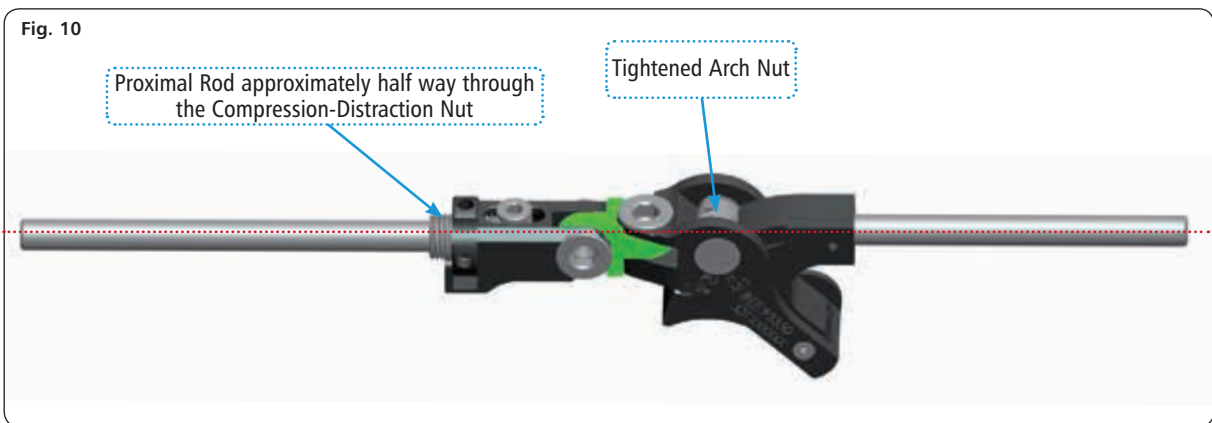

Galaxy Wrist Fixator positioning

- Attach the Wrist Module to the Small Multi-screw Clamp-Short (93330) and close the clamp by hand (Fig. 11)

NOTE: At this stage, both Locking Screws of the Small Multi-screw Clamp-Short should be closed only by hand enabling movement in all planes to locate the centre of rotation

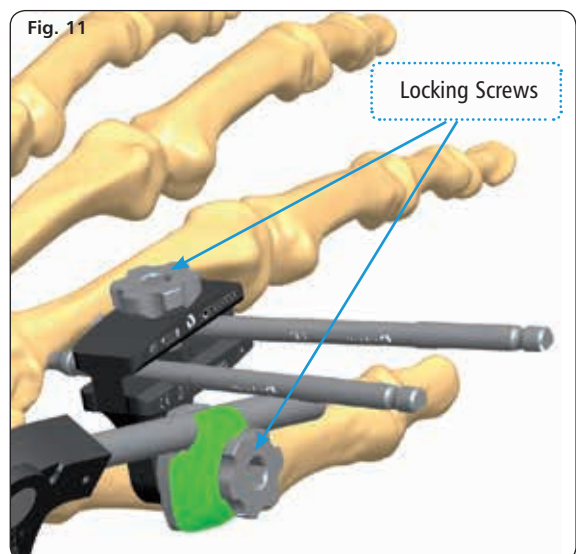

- If necessary a \varnothing 1.5mm K-wire can be used to assist in aligning the fixator with the centre of rotation of the wrist joint, which is located within the head of the capitate¹ in both flexion and extension, and radial and ulnar deviation (Fig. 12)

¹ Neu C.P., Crisco J.J., Wolfe S.W. *In vivo kinematic behavior of the radio-capitate joint during wrist flexion-extension and radio-ulnar deviation. Journal of Biomechanics, 34 (2001): 1429–1438.*

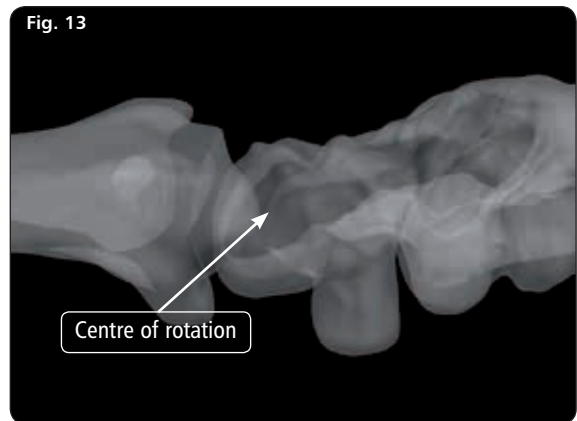
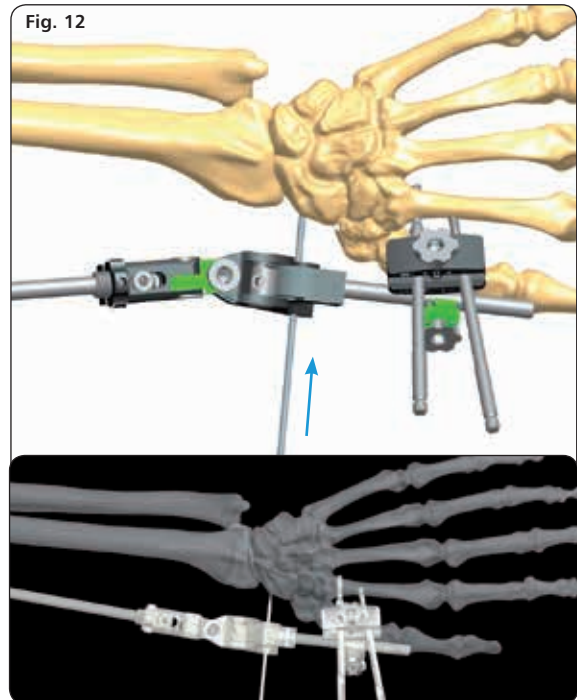

- Under image intensification, identify the centre of rotation of the wrist in AP and Lateral view and ensure that the Wrist Module Central Unit is aligned with it (see figure 13)

CORRECT ALIGNEMENT

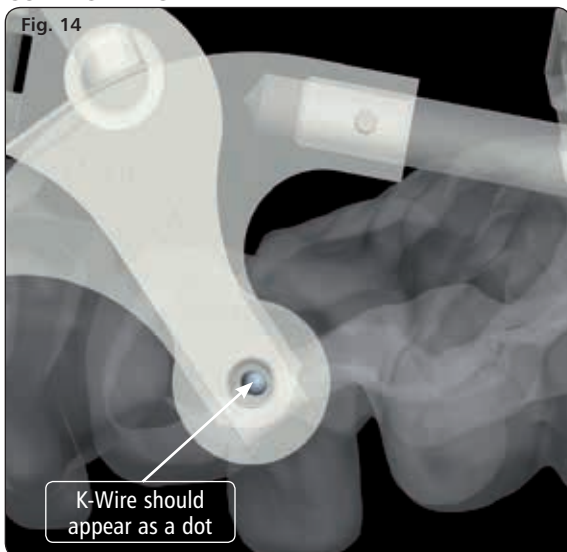

INCORRECT ALIGNEMENT

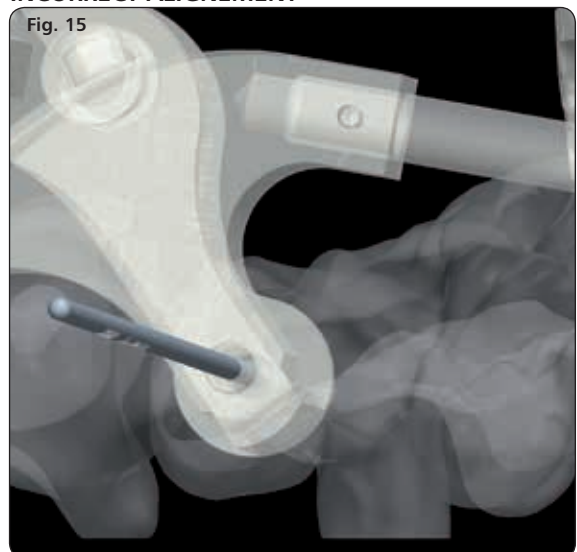

- Once the centre of rotation has been identified, both Locking Screws of the Small Multi-screw Clamp-Short (93330) are locked into position using the Allen Wrench (Fig. 16)

NOTES:

The clamp must be tightened gently in order to preserve the correct alignment, taking care that it is maintained at all times

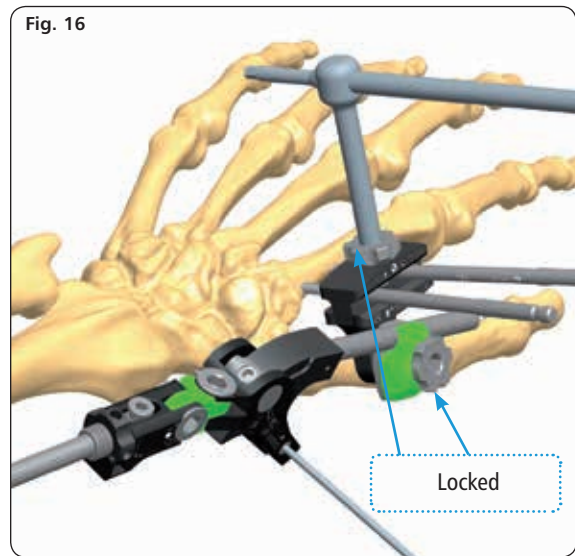

Correct positioning of the proximal rod in ML Plane

- Loosen the ML locking Screw of the central joint (Fig. 17)
- Move the proximal rod to find its best position in this plane

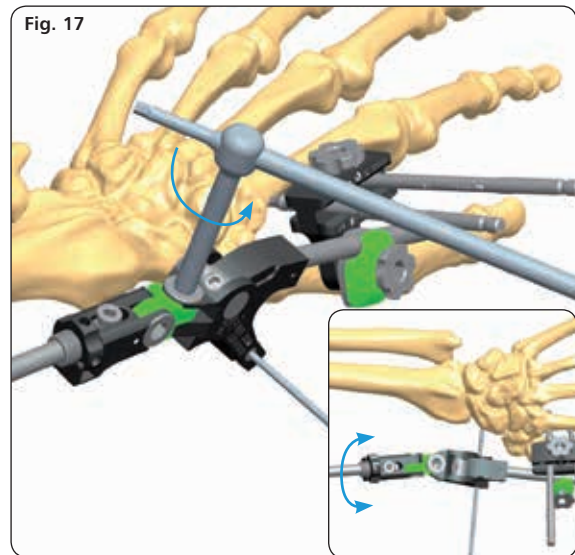

Correct positioning of the proximal rod in AP Plane

- Loosen the AP locking Screw of the central joint (Fig. 18)
- Move the proximal rod to find its best position in this plane

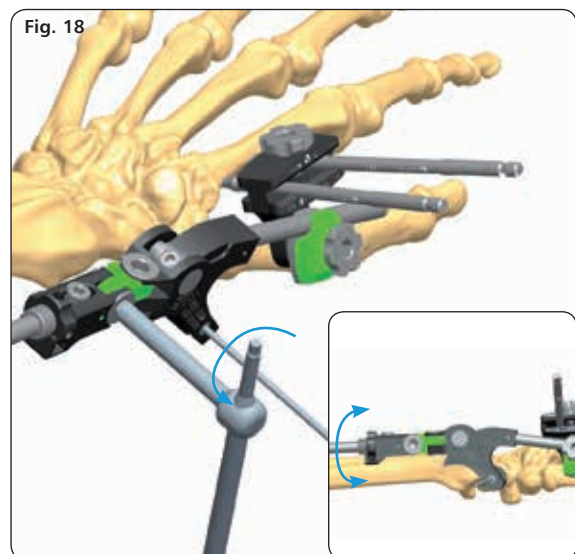

- Mount the second Small Multi-screw Clamp-Short (93330) over the proximal rod and lock it in place
- Make a longitudinal skin incision for each screw
- Dissect the soft tissues down to the bone taking care to retract the soft tissues
- The screw guide is positioned with the trocar over the Small Multi-screw Clamp-Short (93330)

Fig. 19

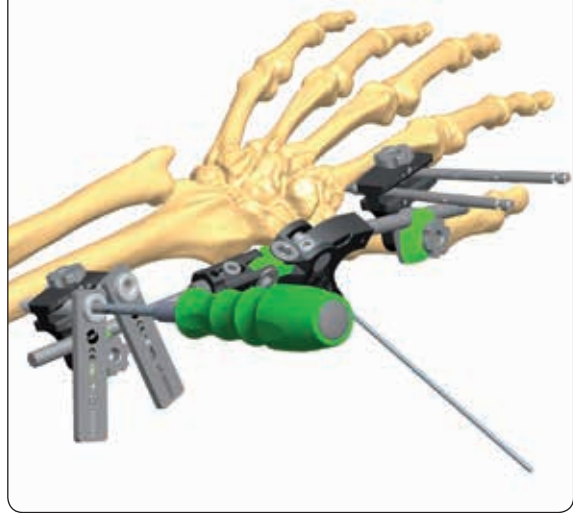

- Insert the proximal screws following one of the below screw insertion techniques (Fig. 20):

*Pre-drilled Bone Screws (4mm shaft) Insertion

- Remove the trocar, replace it with the drill guide and drill the bone over the drill guide with a 2.7mm drill bit
- Insert a bone screw with the T-Wrench 4mm Shaft (93175) or the T-Wrench (M210) over the screw guide

Cylindrical Bone Screws (4mm shaft) and *Self-drilling Bone Screws (3 or 4mm shaft) Insertion

- Remove the trocar and insert the screws directly through the screw guide without pre-drilling. In case of the 4mm cylindrical screws, they are inserted using either the Screw T-Wrench QC (93160) or power drill with moderate speed. In case of the 3mm or 4mm shaft conical screws, they are inserted using either the T-Wrench (M210) or power drill with moderate speed

NOTES:

- Pay attention to the safe corridors during pin insertion, taking care to avoid tendon entrapment and radial nerve damage
- There is no need for the tip of the screw to protrude from the second cortex
- Great care must be taken to ensure that the screws are inserted in the central bone axis
- Once they have been placed, an X-Ray should be used to verify the position and penetration of the far cortex by all four screws
- Remove the screw guides and close the clamp cover by hand (Fig. 21).

* **WARNING:** Due to their tapered design, screws become loose if they are backed out

Fig. 20

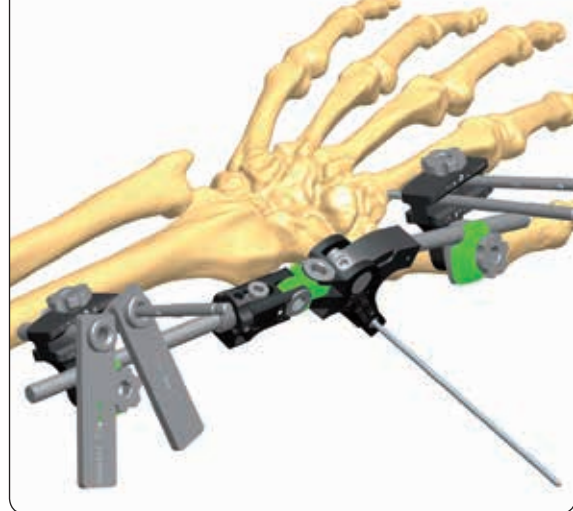
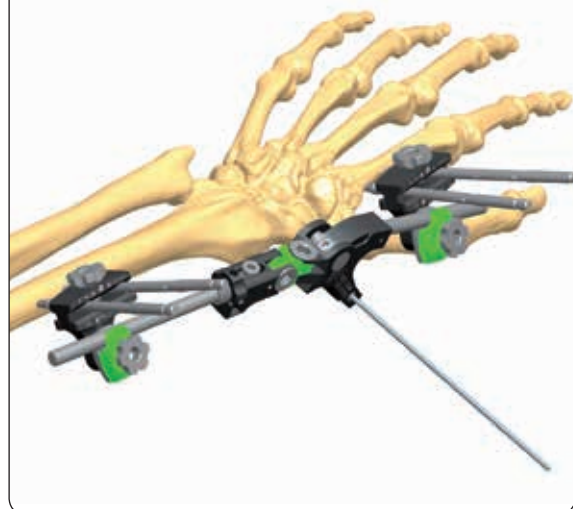
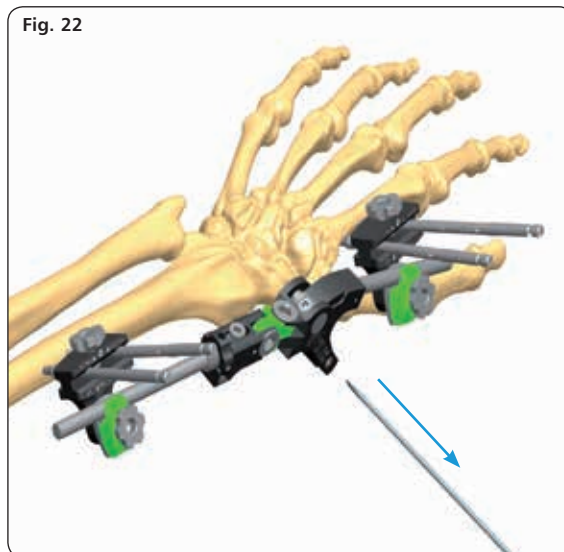

Fig. 21



- Remove the K-wire (Fig. 22)



- Check the joint movement by loosening the nut of the the arch, and, if the movement is correct, lock the Wrist Module in neutral position (Fig. 23)
- Check fracture reduction under X-Ray and if necessary restore the wrist anatomy with the fixator in place before locking all clamps

NOTE: Close tightly both the ML and the AP Locking Screw using the Allen Wrench. If the joint does not move freely, adjust the position of the Wrist Module before locking the Arch Nut and the AP/ML Locking Screws

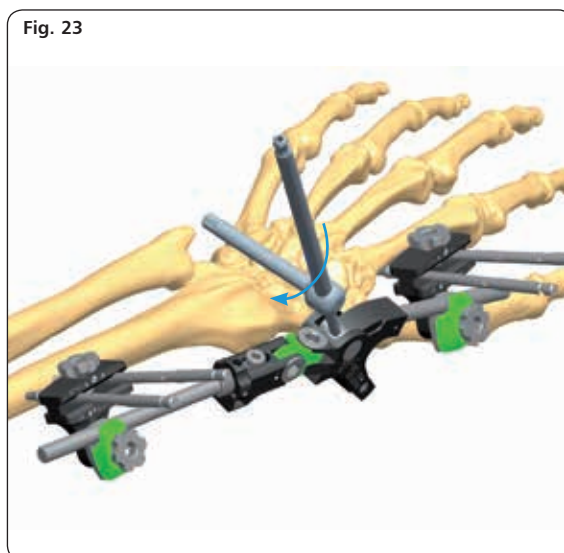

CONTROLLED RANGE OF MOVEMENT

- The system allows for a $\pm 20^\circ$ and $\pm 40^\circ$ controlled flexion-extension movement of the wrist
- In order to achieve this, first loosen the Arch Nut (Fig. 24)

Fig. 24

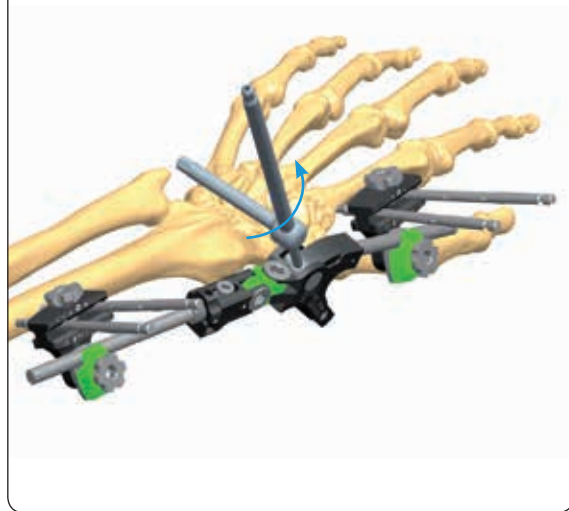

- Push the the Motion Range Selector in its outer seat with the Allen Wrench to gain $\pm 40^\circ$ of freedom (Fig. 25)

Fig. 25

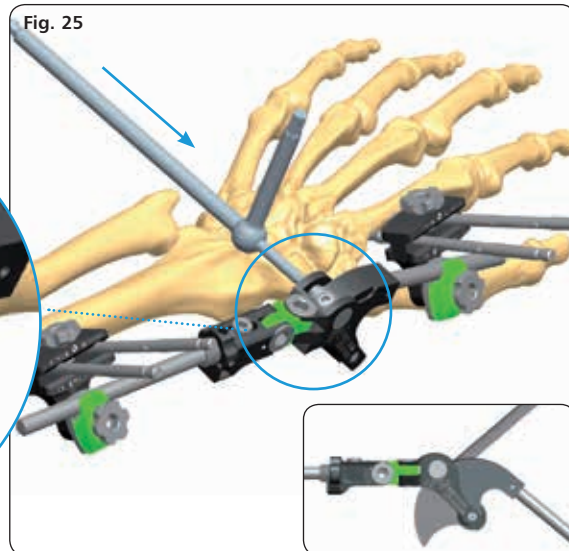

- Push the Motion Range Selector in its inner seat with the Allen Wrench to gain $\pm 20^\circ$ freedom (Fig. 26)

Fig. 26

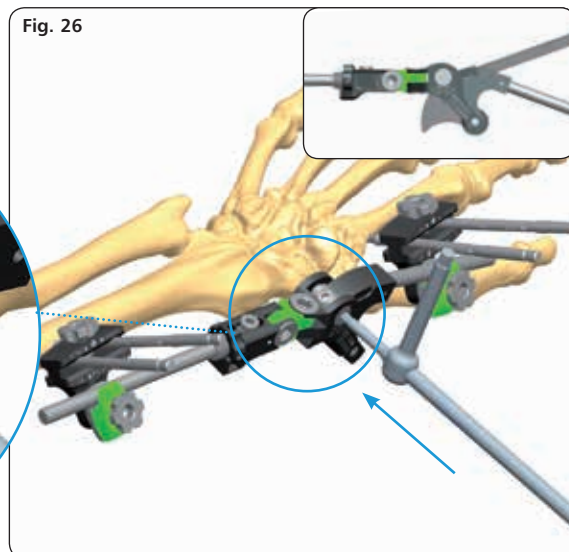

COMPRESSION-DISTRACTION

- Loosen the Compression-Distraction Set Screw (Fig. 27)

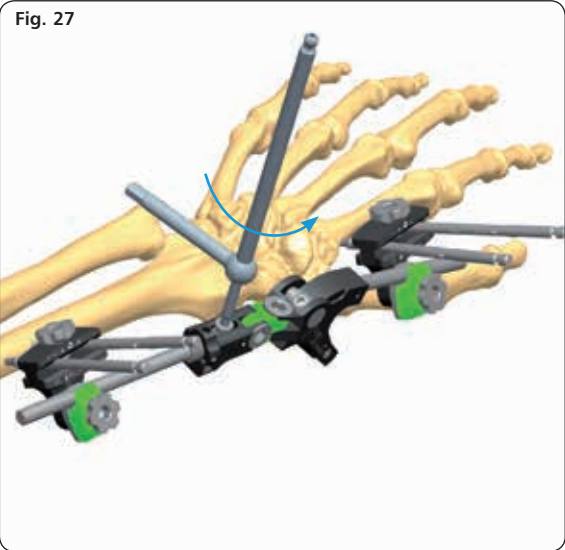

- Using the Allen Wrench, turn the Compression-Distraction Nut clockwise or anti-clockwise to achieve distraction or compression respectively (Fig. 28)

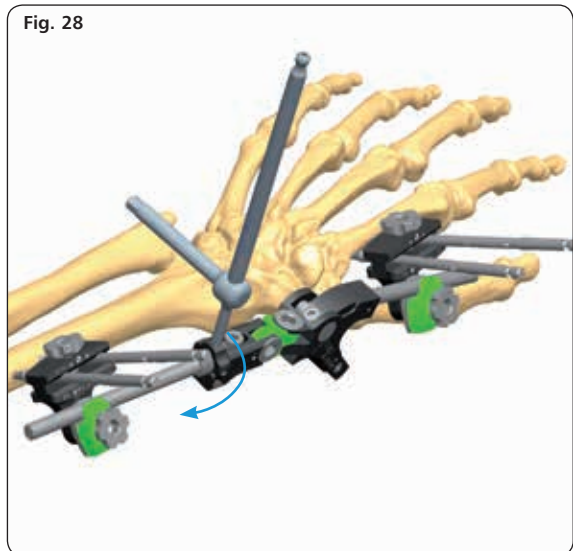

- If necessary, cut the screws shaft with the 4mm Cutter (94101-not provided in the tray) (Fig. 29)

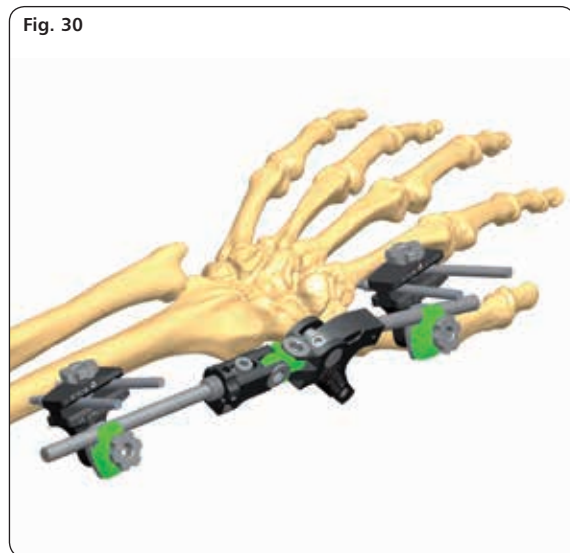
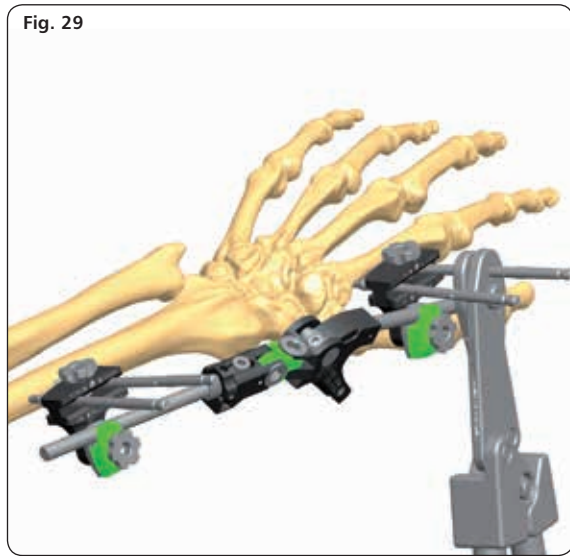

EXTRA-ARTICULAR APPLICATION

- If there is no intra-articular involvement of the fracture line and the epiphyseal fragment has a volar length of 10mm minimum, bridging of the joint is not required and the following technique is applicable

Surgical Area Preparation

- Regional or general anaesthesia may be used
- Tourniquet should be available if desired
- Use a hand table
- Make sure that X-ray equipment is available
- Sterilise the skin over the iliac crest in case a bone graft should be needed
- Reduce approximately the fracture before the fixator is applied
- Place the wrist in moderate (manual) traction, flexion and radial abduction (i.e. ulnar deviation) with a folded towel on the ulnar side to support it (Fig. 31)
- Identify the Lister turbercle and the safe corridors

Distal Screws Insertion

- Make a longitudinal incision to the skin for each screw, making sure to follow safe corridors
- Dissect the soft tissues down to the bone taking care to retract the muscles
- The screw guide is positioned over the bone with the trocar

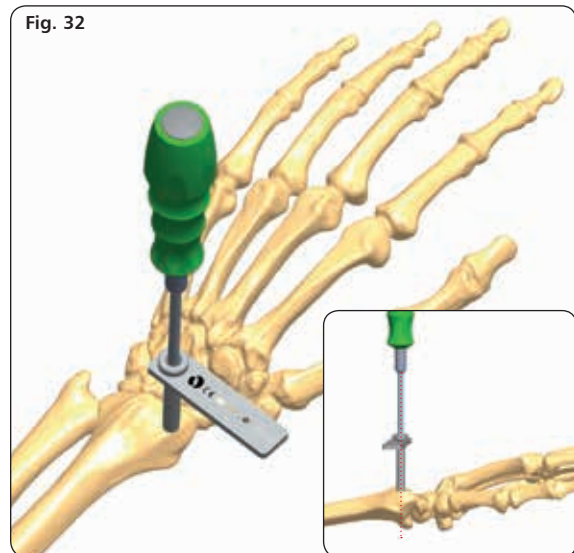
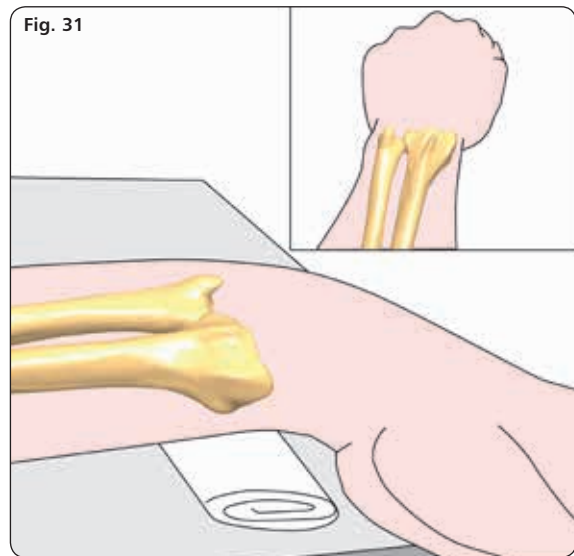

- Insert first the lateral proximal screw following one of screw insertion techniques described below:

***Pre-drilled Bone Screws (4mm shaft) Insertion**

- Remove the trocar, replace it with the drill guide and drill the bone over the drill guide with a 2.7mm drill bit
- Insert a bone screw with the T-Wrench 4mm Shaft (93175) or the T-Wrench (M210) over the screw guide

Cylindrical Bone Screws (4mm shaft) and *Self-drilling Bone Screws (3 or 4mm shaft) Insertion

- Remove the trocar and insert the screws directly through the screw guide without pre-drilling. In case of the 4mm cylindrical screws, they are inserted using either the Screw T-Wrench QC (93160) or power drill with moderate speed. In case of the 3mm or 4mm shaft conical screws, they are inserted using either the T-Wrench (M210) or power drill with moderate speed

NOTES:

- Take care to avoid damage to the radial nerve and the radio-ulnar joint
- After insertion, check by X-Ray the screw positions
- The screw should engage the volar cortex securely and penetrate by one thread
- Carefully evaluate the bone quality before positioning the screws
- There is no need for the tip of the screw to protrude from the second cortex
- Great care must be taken to ensure that the screws have the maximum bone purchase

* **WARNING:** Due to their tapered design, screws become loose if they are backed out

Small Multi-screw Clamp-long positioning

- Insert the Small Multi-screw Clamp-Long (93320) over the first distal screw
- For an easier application of the second screw, it is advisable to temporarily fix a rod to the clamp to be used as handle before positioning the Small Multi-screw Clamp-Long (93320) as described in Fig. 6, Page 43 for the Small Multi-screw Clamp-Short
- Insert the second distal screw following the same procedure described above (Fig. 34)
- Remove the screw guides and close the Locking Screw of the Clamp cover by hand

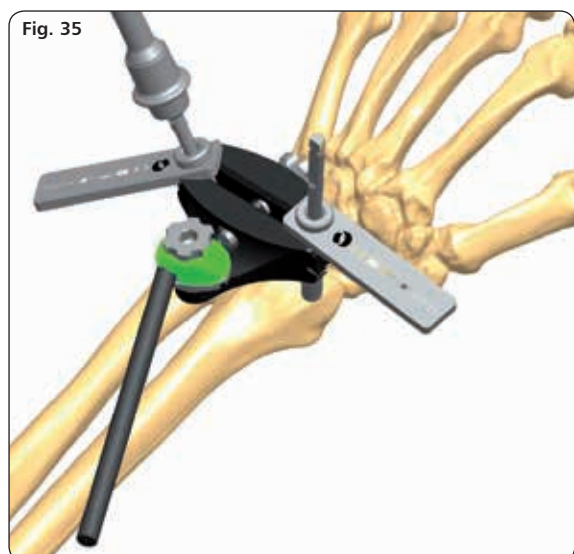
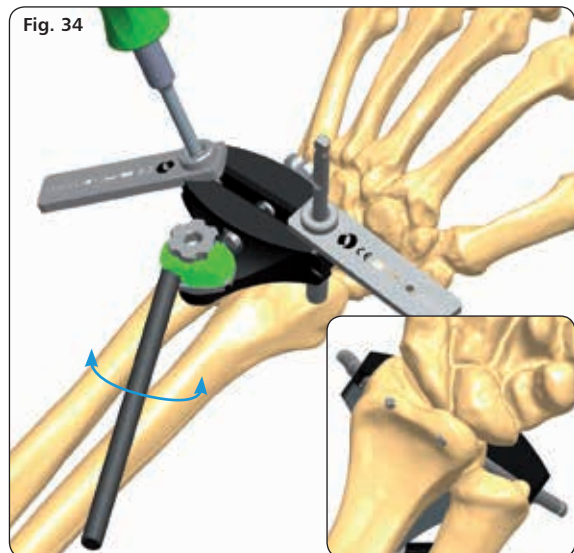
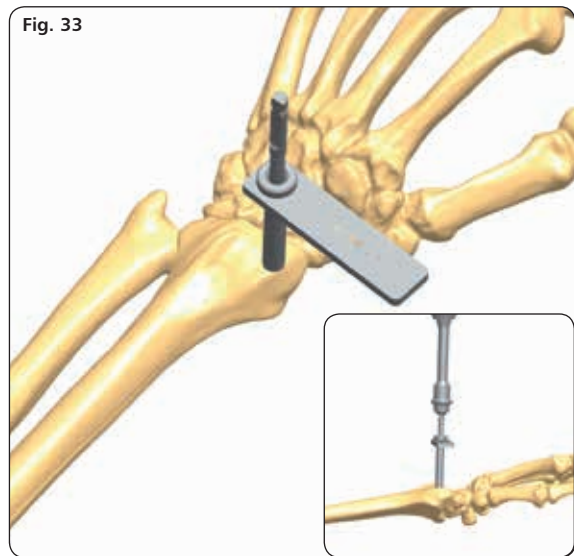

- Attach the L-Rod to the Small Multi-screw Clamp-Long
- Close the clamp by hand (Fig. 36)

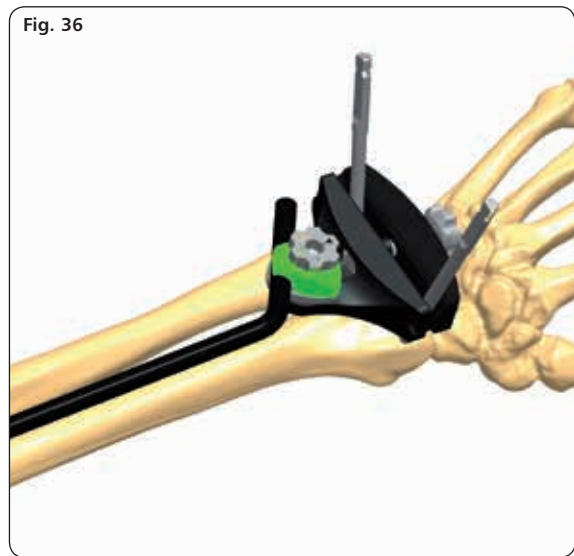

- Insertion of the proximal screws is carried out at a distance of about 14cm from the distal screws depending on the fracture site
- Make a 25mm incision to the skin in order to avoid injury to the superficial branch of the radial nerve
- Screw insertion must follow one of the techniques described above, paying attention to safe corridors (Fig. 37)

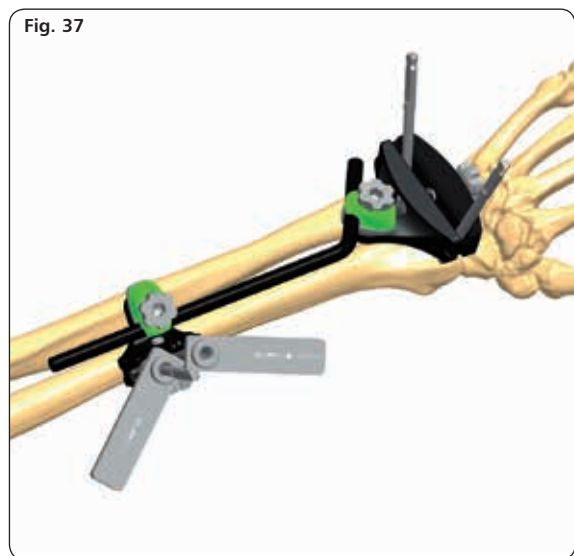

- All clamps are tightened using the Allen Wrench avoiding loss of position (Fig. 38)

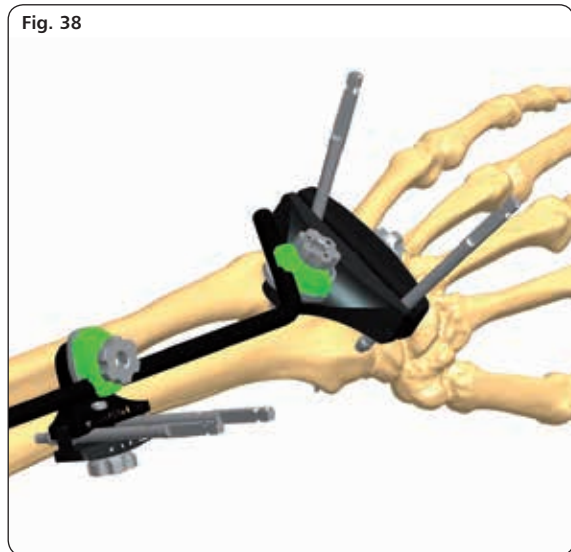

- If necessary cut the screw shafts with the 4mm Cutter (94101-not provided in the tray) (Fig. 39)

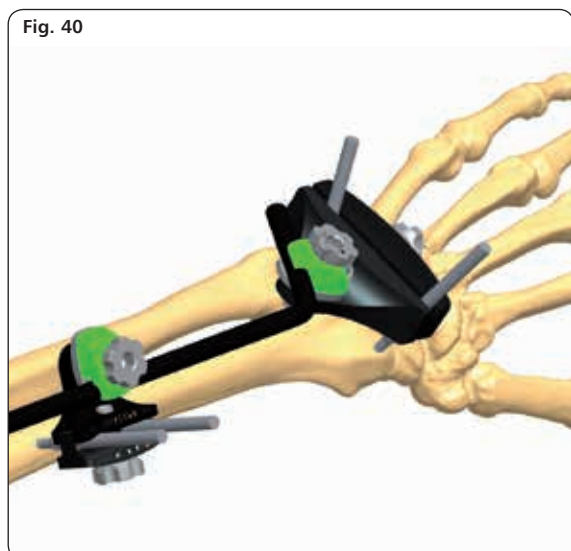
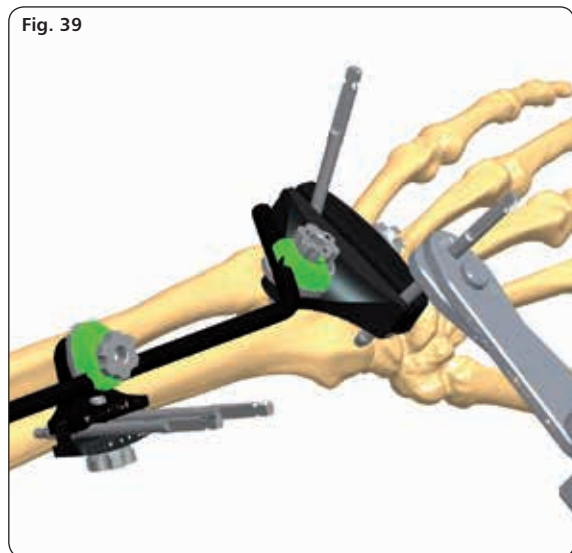

UPPER LIMB APPLICATIONS

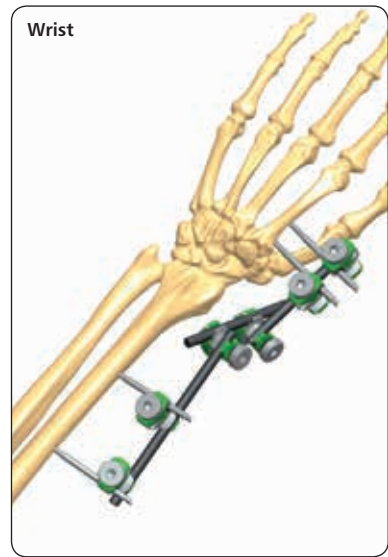
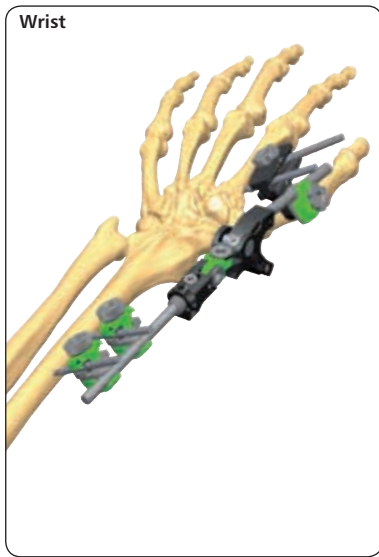

Paediatric applications

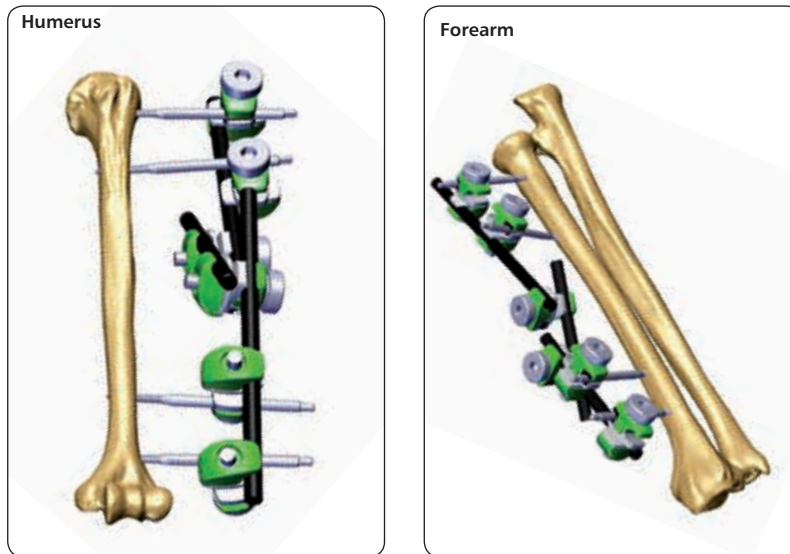

MRI INFORMATION

GALAXY WRIST

Non-clinical testing has demonstrated that the Galaxy Wrist Components are MR Conditional. A patient with the Galaxy Wrist components can be safely scanned under the following conditions:

- Static magnetic field of 1.5 Tesla and 3.0Tesla.
- Maximum spatial magnetic field gradient of 900-Gauss/cm (90mT/cm).
- Maximum MR System reported-whole-body-averaged specific absorption rate (SAR) of <4.0 W/kg (First Level Controlled Operating Mode).
- No local transmit/receive coils must be used on the device.
- The Galaxy Fixation System must be entirely outside the MR scanner bore. No part of the Galaxy Fixation System must extend into the MR bore. Therefore MR scanning of body parts where the Galaxy Fixation System is located is Contraindicated.

Heating Information

Under the scan conditions defined above, the Galaxy Fixation System frames are expected to produce a maximum temperature rise of 1°C after 15 minutes of continuous scanning.

Displacement Information

The system will not present an additional risk or hazard to a patient in the 1.5Tesla and 3Tesla MR environment with regard to translational attraction or migration and torque.

GALAXY FIXATION™ SYSTEM

Galaxy System™ Fixator Components are labeled MR CONDITIONAL  according to the terminology specified in ASTM F2503 Standard Practice for Marking Medical Devices and Other Items in the Magnetic Resonance Environment.

Non-clinical testing has demonstrated that the Galaxy System Fixator Components is MR Conditional according to the terminology specified in ASTM F2503 Standard Practice for Marking Medical Devices and Other Items in the Magnetic Resonance Environment. Non-clinical testing, done according to ASTM F2052-06, F2213-06, F2182-11, F2119-07, demonstrated that a patient with the Galaxy Fixation System can be safely scanned under the following conditions:

- Static magnetic field of 1.5 Tesla and 3.0Tesla
- Maximum spatial magnetic field gradient of 900-Gauss/cm (90mT/cm)
- Maximum whole-body-averaged specific absorption rate (SAR) of 4.0 W/kg in the First Level Controlled Mode for 15 minutes of scanning.
- No local transmit/receive coils must be used on the device.
- The Galaxy Fixation System must be entirely outside the MR scanner bore. No part of the Galaxy Fixation System must extend into the MR bore. Therefore MR scanning of body parts where the Galaxy Fixation System is located is Contraindicated.

Heating Information

Comprehensive electromagnetic computer modeling and experimental testing was performed on the following systems:

- 1.5-Tesla/64-MHz: Magnetom, Siemens Medical Solutions, Malvern, PA. Software Numaris/4, Version Syngo MR 2002B DHHS Active-shielded, horizontal field scanner
- 3-Tesla/128-MHz: Excite, HDx, Software 14X.M5, General Electric Healthcare, Milwaukee, WI, Active-shielded, horizontal field scanner

to determine the worst heating in seven configurations of Orthofix Galaxy Fixation™ System. From these studies, it is concluded that once the entire external fixation frame is visible outside the MRI bore, the maximum heating is less than 2 degree Celsius. In non-clinical testing the worst scenarios produced the following temperature rises during MRI under the conditions reported above:

	1.5 Tesla System	3.0 Tesla System
Galaxy Fixation™ System		
Minutes of scanning	15	15
Calorimetry measured values, whole body averaged SAR (W/kg)	2.2 W/Kg	2.5 W/Kg
Highest temperature Rise less than (°C)	2 C	2 C

Please note that temperature changes reported apply to the designed MR systems and characteristics used. If a different MR system is used, temperature changes may vary but are expected to be low enough for safe scanning as long as all Galaxy System Fixator Components are placed **outside** the MR bore.

Displacement Information

The system will not present an additional risk or hazard to a patient in the 1.5Tesla and 3Tesla MR environment with regard to translational attraction or migration and torque.

MR PATIENT SAFETY

MRI in patients with Galaxy Fixation System can only be performed under these parameters. It is not allowed to scan the Galaxy Fixation™ System directly. Using other parameters, MRI could result in serious injury to the patient. When the Galaxy Fixation System is used in conjunction with other External Fixation Systems please be advised that this combination has not been tested in the MR environment and therefore higher heating and serious injury to the patient may occur. Because higher in vivo heating cannot be excluded, close patient monitoring and communication with the patient during the scan is required. Immediately abort the scan if the patient reports burning sensation or pain.

Galaxy Fixation System can only be guaranteed for MRI when using the following components to build a frame:

NOTE:*the following components are listed in non-sterile configuration. Please consider that the same MRI information and performance are applicable to the same components in gamma-sterile configuration, code number preceded by 99- (e.g 99-93030).

RODS*

Code	Description
932100	Rod 100mm long, 12mm diameter
932150	Rod 150mm long, 12mm diameter
932200	Rod 200mm long, 12mm diameter
932250	Rod 250mm long, 12mm diameter
932300	Rod 300mm long, 12mm diameter
932350	Rod 350mm long, 12mm diameter
932400	Rod 400mm long, 12mm diameter
99-932450	Rod 450mm long, 12mm diameter, sterile**
99-932500	Rod 500mm long, 12mm diameter, sterile**
99-932550	Rod 550mm long, 12mm diameter, sterile**
99-932600	Rod 600mm long, 12mm diameter, sterile**
99-932650	Rod 650mm long, 12mm diameter, sterile**
939100	Rod 100mm long, 9mm diameter
939150	Rod 150mm long, 9mm diameter
939200	Rod 200mm long, 9mm diameter
939250	Rod 250mm long, 9mm diameter
939300	Rod 300mm long, 9mm diameter
936060	Rod 60mm long, 6mm diameter
936080	Rod 80mm long, 6mm diameter
936100	Rod 100mm long, 6mm diameter
936120	Rod 120mm long, 6mm diameter
936140	Rod 140mm long, 6mm diameter
936160	Rod 160mm long, 6mm diameter
936180	Rod 180mm long, 6mm diameter
936200	Rod 200mm long, 6mm diameter

** Special order only.

CLAMPS*

Code	Description
93010	Large Clamp
93110	Medium Clamp
93310	Small Clamp
93020	Multi-Screw Clamp
93030	Large-Medium Transition Clamp
93120	Medium Multi-Screw Clamp
99-93040	Large Double Multiscrew Clamp
99-93140	Medium Double Multiscrew Clamp

GALAXY WRIST*

Code	Description
93320	Small Multi-screw Clamp-LONG
93330	Small Multi-screw Clamp-SHORT
93350	Wrist Module

ELBOW HINGE*

Code	Description
93410	Elbow Hinge

XCALIBER CYLINDRICAL BONE SCREWS*

Code	Shaft Ø	Thread Ø	Total L	Thread L
942630	6	6	260	30
942640	6	6	260	40
942650	6	6	260	50
942660	6	6	260	60
942670	6	6	260	70
942680	6	6	260	80
942690	6	6	260	90
941630	6	6	180	30
941640	6	6	180	40
941650	6	6	180	50
941660	6	6	180	60
941670	6	6	180	70
941680	6	6	180	80
941690	6	6	180	90
942540	6	5	260	40
942550	6	5	260	50
942560	6	5	260	60
942570	6	5	260	70
942580	6	5	260	80
942590	6	5	260	90
943540	6	5	220	40
943550	6	5	220	50
943560	6	5	220	60
943570	6	5	220	70
941540	6	5	180	40
941550	6	5	180	50
941560	6	5	180	60
944530	6	5	150	30
944535	6	5	150	35
944540	6	5	150	40
944550	6	5	150	50
945530	6	5	120	30
945535	6	5	120	35
945540	6	5	120	40
946420	6	4	180	20
946430	6	4	180	30
946440	6	4	180	40
945420	6	4	150	20
945430	6	4	150	30
945440	6	4	150	40
944420	6	4	120	20
944430	6	4	120	30
944440	6	4	120	40
943420	6	4	100	20
943430	6	4	100	30
943440	6	4	100	40
948320	4	3	120	20
948325	4	3	120	25
948335	4	3	120	35
947320	4	3	100	20
947325	4	3	100	25
M310	3	3 - 2,5	50	18
M311	3	3 - 2,5	60	20
M312	3	3 - 2,5	60	25
M313	3	3 - 2,5	60	30
M321	3	3 - 2,5	70	15
M314	3	3 - 2,5	70	20
M315	3	3 - 2,5	70	25
M316	3	3 - 2,5	70	30
M317	3	3 - 2,5	100	30

References

- 1) Summary, conclusions and recommendations: adverse temperature levels in the human body. Goldstein L.S., Dewhirst M.W., Repacholi M., Kheifets L. Int. J. Hyperthermia Vol 19 N. 2003 pag 373-384.
- 2) Assessment of bone viability after heat trauma Eriksson R.A., Albrektsson T., Magnusson B. Scand J Plast Reconstr Surg 18:261-68 1984.
- 3) Temperature threshold levels for heat-induced bone tissue injury: A vital-microscopic study in the rabbit Eriksson A.R., Albrektsson T. J Prosthet Dent. 1983 Jul;50(1):101-7.

XCALIBER BONE SCREWS*

Code	Shaft Ø	Thread Ø	Total L	Thread L
912630	6	6 - 5,6	260	30
912640	6	6 - 5,6	260	40
912650	6	6 - 5,6	260	50
912660	6	6 - 5,6	260	60
912670	6	6 - 5,6	260	70
912680	6	6 - 5,6	260	80
912690	6	6 - 5,6	260	90
911530	6	6 - 5,6	150	30
911540	6	6 - 5,6	150	40
911550	6	6 - 5,6	150	50
911560	6	6 - 5,6	150	60
911570	6	6 - 5,6	150	70
911580	6	6 - 5,6	150	80
911590	6	6 - 5,6	150	90

BONE SCREWS*

Code	Shaft Ø	Thread Ø	Total L	Thread L
10190	6	4,5 - 3,5	70	20
10191	6	4,5 - 3,5	80	20
10108	6	4,5 - 3,5	80	30
10135	6	4,5 - 3,5	100	20
10136	6	4,5 - 3,5	100	30
10105	6	4,5 - 3,5	100	40
10137	6	4,5 - 3,5	120	20
10138	6	4,5 - 3,5	120	30
10106	6	4,5 - 3,5	120	40
35100	4	3,3 - 3	70	20
35101	4	3,3 - 3	80	35

The Orthofix Galaxy Fixation System components not listed above have not been tested for heating, migration, or image artifact in the MR environment, and their safety is unknown. Scanning a patient carrying a frame that includes these components may result in patient injury.

* Products may not be available in all markets because product availability is subject to the regulatory and/or medical practices in individual markets. Please contact your Orthofix representative if you have questions about the availability of Orthofix products in your area.

Electronic Instructions for use available at the website
<http://ifu.orthofix.it>

Electronic Instructions for use - Minimum requirements for consultation:

- Internet connection (56 kbps)
- Device capable to visualize PDF (ISO/IEC 32000-1) files
- Disk space: 50Mbytes

Free paper copy can be requested to customer service (delivery within 7 days):
tel +39 045 6719301, fax +39 045 6719370,
e-mail: customerservice@orthofix.it

Distributed by:

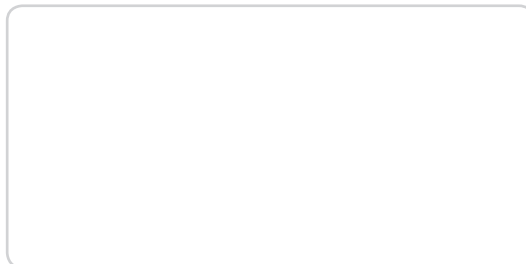

Manufactured by:
ORTHOFIX Srl
Via Delle Nazioni 9, 37012 Bussolengo (Verona), Italy
Telephone +39 045 6719000, Fax +39 045 6719380



Caution: Federal law (USA) restricts this device to sale by or on the order of a physician. Proper surgical procedure is the responsibility of the medical professional. Operative techniques are furnished as an informative guideline. Each surgeon must evaluate the appropriateness of a technique based on his or her personal medical credentials and experience. Please refer to the "Instructions for Use" supplied with the product for specific information on indications for use, contraindications, warnings, precautions, adverse reactions and sterilization.